

III. *Electrodynamic Qualities of Metals.*—Part VII. *Effects of Stress on the Magnetization of Iron, Nickel, and Cobalt.*

By Professor Sir WILLIAM THOMSON, F.R.S.

Received May 9,—Read May 23, 1878.

[PLATES 2-13.]

§§ 198 and 199.

198. IN a preliminary notice of investigations regarding the effects of stress on inductive magnetization in soft iron, communicated to the Royal Society on the 10th of June, 1875, I described experiments which afforded a complete explanation of the seeming anomalies referred to in §§ 194 and 195,* which had at first been so perplexing. These experiments showed that the diminution of magnetism in a soft iron wire, which I had found to be produced by pull, while the wire was under the influence of a constant magnetizing force, was to be observed only when the magnetizing force exceeded a certain critical value, and that when the magnetizing force was below that critical value the effect of pull was to increase the magnetism—a result which I afterwards found had been previously obtained by VILLARI.† The critical value of the magnetizing force I found to be about twenty-four times the vertical component of the terrestrial magnetic force at Glasgow. Hence the magnetizing force which I had used in my first experiment, which (§ 183) was nearly 300 times the vertical component of the terrestrial force, must have been about twelve times as great as the critical value. Further (which was most puzzling), I found the absolute amount of the effects of pull to be actually greater with the small magnetizing force of the earth than that of the opposite effects of the 300-fold greater magnetizing force of my early experiments. Thus the effect of the terrestrial force was not only in the right direction, but was of amply sufficient amount to account for the seeming anomalies which had at first been so perplexing; and in going over the details of the old observations I find all the anomalies quite explained. One of them, that particularly referred to in § 195, is still interesting. The alternate augmentation of the residual magnetism by “on” and diminution of it by “off,” with the weight of 14 lbs., corresponded to the normal effect on residual magnetism in soft iron. The elongation of 8 per cent. produced when the 28 lbs. was hung on, was no doubt accompanied by a shaking out of nearly all the residual magnetism, and an inductive magnetization in the opposite direction by the vertical component of

* Phil. Trans. for 1876, p. 710 (Read May 27, 1875).

† POGGENDORFF'S ‘Annalen,’ 1868; also WIEDEMANN'S ‘Galvanismus,’ vol. ii., § 499.

the earth's magnetic force. The reversed effects of the "ons" and "offs," observed after this change, were really augmentations and diminutions of magnetism induced by the earth's vertical force, and were therefore the proper effects for soft iron when subject to a magnetizing force of less than the VILLARI critical value. Further experimental investigation is necessary to explain the *greater amount* of effect, the same in kind as those observed before the stretching by 28 lbs., which the wire showed after it had been stretched by this weight.

199. The experiments indicated in my preliminary notice of June 10, 1875, were the commencement of an elaborate series of investigations by Mr. ANDREW GRAY and Mr. THOMAS GRAY, which have been continued with little intermission from that time until now, and which are still in progress, with the general object of investigating the effects of longitudinal and transverse stress upon the magnetization of different qualities of iron and steel, and of nickel and cobalt. A separate series of investigations was made nearly two years ago by Mr. DONALD MACFARLANE on the effects of torsion on the magnetization of soft iron, bringing out some very remarkable results, also included in this paper (§§ 223–229, below).

§§ 200–212. *Investigation by the Ballistic* method, of the change of Magnetization produced in a specimen of exceedingly soft Iron Wire, by the application and removal of pulling force.*

200. The wire used in these experiments was specially prepared for this investigation by Messrs. RICHARD JOHNSON and Nephew, Manchester. It was of No. 22 Birmingham wire gauge; its weight per metre was 3·47 grammes, and its diameter was ·075 of a centimetre. A steel pianoforte wire of the same gauge would bear about 230 lbs. on and off, without experiencing in consequence any permanent change of quality. This iron wire was so soft that, after it was stretched by a scale-pan weighing 1 lb., which thenceforth was kept always hanging on it, an additional weight of 14 lbs. on and off gave a permanent elongation of ·4 per cent., and 4 lbs. more gave it a further permanent elongation of 1·6 per cent. (making in all 2 per cent. of permanent elongation produced by 18 lbs. on and off, the permanent weight of 1 lb. being always on). The weight of 18 lbs. was applied and removed several times on the 14th of May, without producing any more permanent elongation than the 1·6 per cent. which was observed after the first on and off. During three-quarters of a year after that day no weight of more than 14 lbs. (in addition to the permanent 1 lb.) was ever applied to the wire, and electro-magnetic experiments were made upon it from day to day, with little intermission, with "ons" and "offs" of 14 lbs., but sometimes with 7 lbs. During all this time the length of the wire (about 4 metres) remained sensibly constant for the same weight, and the wire experienced regular elastic elongations

* Compare §§ 178, 179. Phil. Trans. for 1876, p. 693.

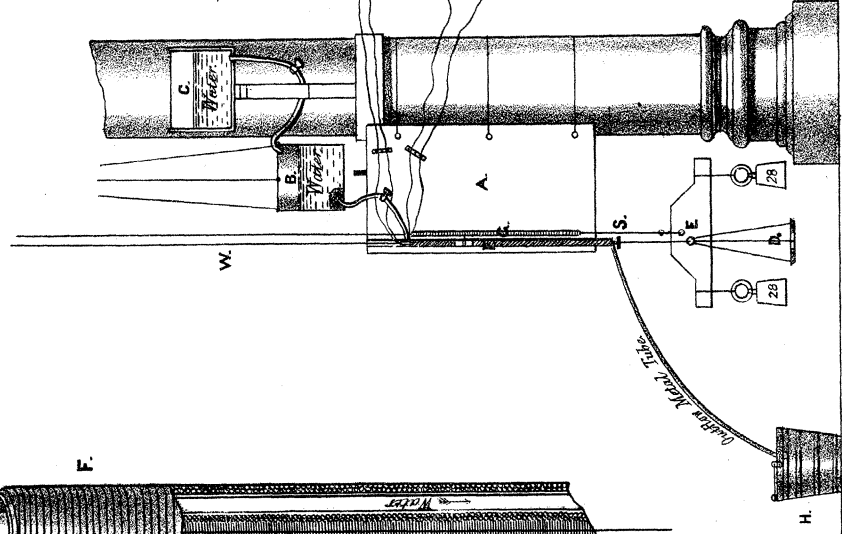
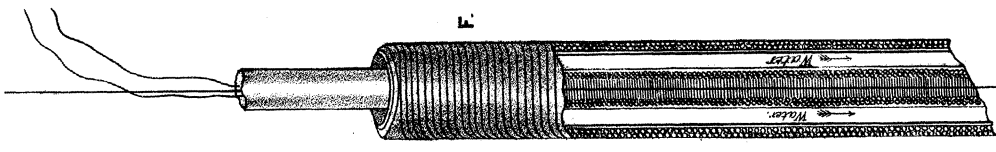

Ballistic Galvanometer.

Battery Galvanometer

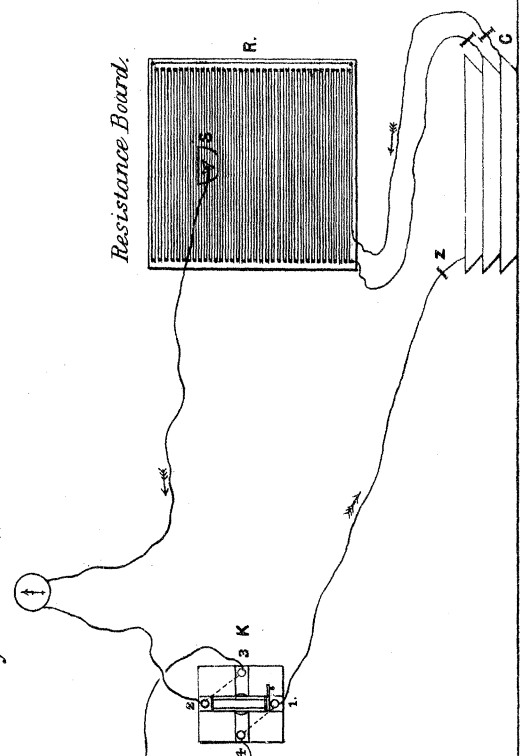

IX.

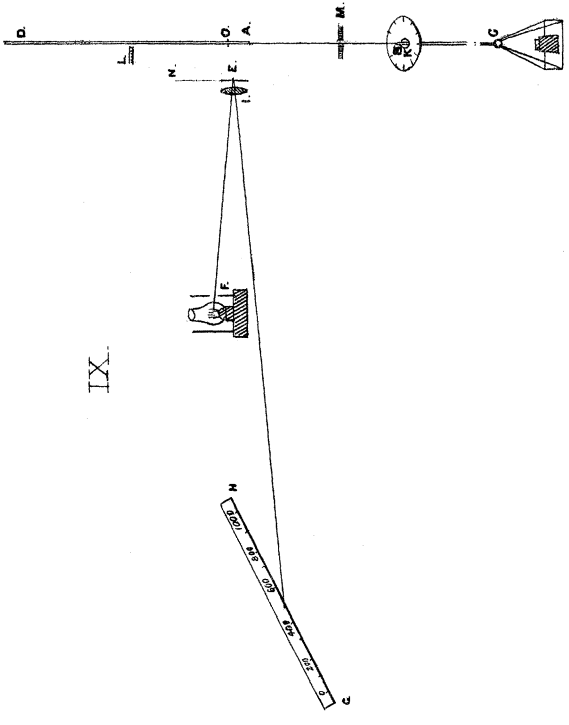

and contractions when the weights were applied and removed. In some of the experiments with "ons" and "offs" of 14 lbs., about 90 centims. of the wire were heated to 100° C. by a stream of hot water (as described in § 201), but this left no permanent change in the wire.

201. The accompanying diagram (I.) shows the arrangement of the apparatus by means of which the results were obtained. The wire, W, experimented on was attached to a fixed support near the ceiling of the laboratory, and hung vertically downward, passing along the common axis of the magnetizing and induction coils, F, and was kept stretched by the scale-pan, D, which, as stated above, weighed exactly 1 lb. The coils, F, were supported on a clamp attached to the wire at their lower end, as shown in the drawing; and thus, as the length of the induction coil was small compared with the total length of the wire, motion of the wire relatively to the induction coil due to the stretching produced by the applied stress, was in great measure avoided. The magnetizing coil was 86 centims. long, and was composed of two layers of silk-covered copper wire. The inner layer contained 26·7 metres of wire, of No. 23 B.W.G., arranged in a solenoid* of 960 turns, the outer layer, 24·3 metres of No. 20 wire, arranged in a solenoid of 728 turns. The resistance per metre of these wires was ·0673 and ·0522 ohm respectively, and the total resistance of the coil after it was wound was 3·134 ohms. The total length of the induction coil, which was contained within the magnetizing coil, was 31·5 centims. It was made up of two layers of silk-covered copper wire, of No. 29 B.W.G., laid on in 1439 turns. The wire thus coiled on was 10 metres long, and had a resistance of ·184 ohm per metre, and the total resistance of the coil, including 1 metre of electrodes, was 2·204 ohms.

The magnetizing coil was wound on the outside of a compound tube, made up of two tubes of thin brass, of different diameters, placed one within the other with their axes coincident, the external diameter of the inner tube being less than the internal diameter of the outer by about 3 millims. The induction coil, which was wound on a thin copper tube just fitting the wire experimented on, was enclosed within the inner brass tube in such a position that its ends were at equal distances from the extremities of the magnetizing coil. The space between the two brass tubes formed a channel

* The common use of the word "helix" in this sense is utterly illogical. The idea of helix is not essential, but accidental, and in no practical case is it of any consequence whether it is a right-handed or a left-handed helix. There is nothing of helical quality in a cylindrical tube composed of two metals in two parts of its circumference, with the junctions of these metals kept at unequal temperatures. The thermo-electric current round the circumference of the solenoid produces the kind of magnetizing influence which is commonly produced by a helix, and constitutes precisely the arrangement which AMPÈRE called a solenoid. It is only because the ordinary helix, with electric current flowing through it, produces more or less approximately (very approximately indeed in the case of a helix with many turns) the same effect, that it is available for the electro-magnetic uses. It seems desirable, therefore, to take advantage of AMPÈRE'S original word "solenoid," and, except in cases in which the helical quality is taken into account, to give up the name "helix." The electro-magnetic solenoid may also be called a bar electro-magnet without soft iron core.

through which water could be made to flow from the cistern B, and thus, by regulation of the temperature of the water in B, the part of the wire within the magnetizing coil could be kept at any temperature from about 10° to nearly 100° C.

202. In order that the elongation and contractions produced in the wire by the applications and removals of the pulling stress might be observed, a second wire was hung from the same support, and kept stretched by two 28 lb. weights, hung from the ends of the cross-bar, E. To this wire a scale of half a millim. was vertically attached, in such a position that a pointer fixed to the magnetizing coil moved along it as the coil moved downward or upward with the application or removal of the weight.

203. The electrodes of the magnetizing coil were connected with the studs 3 and 4 of the commutator, K. One of the other pair of studs was connected with the zinc pole of a battery of my tray DANIELLS, the other stud with the sliding piece of a resistance-slide, R. This slide was designed for the purpose of allowing the battery strength to be raised continuously from 0 to nearly 1 cell, and from 1 cell to nearly 2 cells, and so on. It consisted of a contact-making slider, S, movable along a bare copper wire connecting the two poles of the cell to be sub-divided. This wire, which was 64 metres in length, and had a resistance of 0.67 ohm, was stretched for convenience alternately from one side to the other of a large board, in the manner represented in the diagram. Thus, with the number of cells and arrangement of connexions figured in the diagram, when the slider was brought up as nearly as possible to C, the current flowing was very nearly that due to 3 cells, and when the slider made contact at any other point of the wire, the current flowing through the magnetizing coil was less than that due to 3 cells by an amount depending on the distance along the wire of the slider from C.

204. A galvanometer, the resistance of which was only a very small fraction of an ohm, was used to measure the strength of the magnetizing current, and was so placed in the circuit that the current always flowed through it in the same direction: thus the whole range of the galvanometer scale was available for measuring the deflections produced by the stronger currents used, without the necessity for shifting the zero of the scale by means of a magnet. In these experiments at first the battery galvanometer was placed for convenience in the circuit between the commutator K and the coils F, and a reversing key used to keep the current through it always in the same direction, but it was afterwards transferred to the position in the circuit shown in the diagram and the reversing key dispensed with. The deflections of the needle of this galvanometer were read on a scale of half millimetres placed at a distance of 75 centims. from the mirror, and were used as the values of the magnetizing forces for the abscissas of the curves below. The total resistance in the circuit of the magnetizing coil, which was measured from time to time in the course of the experiments, and showed little or no variation, was 3.828 ohms. The induction coil was placed in circuit with an astatic galvanometer (described in Part VI., § 181, and called in that

paper the ballistic galvanometer), the "throw" of which, as observed on a scale placed 120 centims., or 2400 of its own divisions, from the mirror, measured the strength of the induced current. This galvanometer was placed within a case of thin sheet copper, and the whole enclosed within a glass bell jar to guard it from the effects of currents of air.

205. The procedure in experimenting was similar to that described in Part VI., § 186 (Trans. for 1876, p. 697). One observer took the readings of the ballistic galvanometer, and made and broke the circuit of the magnetizing current; while a second, on word of command from the first, applied or removed the weight, and noted the elongations or contractions of the wire, as shown by the pointer and scale described above. The results were entered in the register on the system followed in my previous experiments, according to which $+M$ denoted that the current was made in such a direction as to cause the image on the scale of the ballistic galvanometer to move towards the right or towards increasing numbers; $-M$, that the current was made in the contrary direction; B, that the current was stopped; Z, the zero of the ballistic galvanometer scale; "On," the application of the weight; and "Off," its removal. The polarity of the magnetization produced in the wire by $+M$ was the same as that shown by the wire when under the influence alone of the vertical component of the earth's magnetic force; and consequently a deflection of the image on the scale of the ballistic galvanometer towards the right, produced by a change in the magnetic condition of the wire after it had been thus magnetized, indicated an increase of its magnetization, and a deflection to the left a diminution of its magnetization. This magnetization produced by $+M$, I shall call positive magnetization, and that produced by $-M$ negative magnetization. Hence a deflection of the ballistic image towards the right indicates an increase of positive magnetization, and a deflection towards the left, a diminution of positive, or an increase of negative, magnetization.

206. The conclusions of the preliminary notice of June 17, 1876, and the statements of § 198, are proved by the following table of results obtained by a very careful repetition of the experiments referred to in that notice. The first column of results in the table gives the operations in the order in which they were performed; the second, the deflections of the image on the scale of the ballistic galvanometer obtained after each operation; and the third column gives the battery strengths. During the whole of the experiments cold water was kept flowing from the cistern B through the channel between the coils to the vessel H, to prevent any heating of the coils and wire by the passage of the magnetizing current. The amount of the elongation and contraction of the wire by the application and removal of the weight of 14 lbs. was constant throughout the experiments. The experiment was begun with zero current in each case, and the weight of 14 lbs. applied and removed until equal and opposite effects were obtained by on and off; and the same process was followed after each augmentation of the magnetizing current. The table contains for each step only the results obtained after this state had been reached.

TABLE I.—Temperature of Cold Water.

Results for + M.			Results for - M.		
Operations.	Deflections.	Current strengths.	Operations.	Deflections.	Current strengths.
14 on	+26	0	14 on	0	11
„ off	-26		„ off	0	
„ on	+33	10	„ on	-27	22
„ off	-33		„ off	+27	
„ on	+36	22	„ on	-36	46
„ off	-36		„ off	+36	
„ on	+36·5	44	„ on	-36·5	66
„ off	-36·5		„ off	+36·5	
„ on	+33·5	67	„ on	-33·5	96
„ off	-33·5		„ off	+33·5	
„ on	+19	143	„ on	-25	145
„ off	-19		„ off	+25	
„ on	+12	180	„ on	-19	169
„ off	-12		„ off	+19	
„ on	+ 6	220	„ on	-15	195
„ off	- 6		„ off	+15	
„ on	+ 2	246	„ on	-11	223
„ off	- 2		„ off	+11	
„ on	0	267	„ on	- 4	267
„ off	0		„ off	+ 4	
„ on	- 4	310	„ on	0	290
„ off	+ 4		„ off	0	
„ on	- 7·5	352	„ on	+ 5	355
„ off	+ 7·5		„ off	- 5	
„ on	- 9	403	„ on	+ 7·5	394
„ off	+ 9		„ off	- 7·5	
„ on	-11	447	„ on	+ 9	430
„ off	+11		„ off	- 9	
„ on	-11·5	503	„ on	+13	830
„ off	+11·5		„ off	-13	
„ on	-12	600			
„ off	+12				
„ on	-13	830			
„ off	+13				

207. We see from the above table that the vertical component of the magnetizing force of the earth is balanced by an opposite magnetizing force due to a current measured by 11 divisions of the battery galvanometer, or about $\frac{1}{5}$ of the VILLARI critical value of the magnetizing force, with 14 lbs. “off” and “on.”

If now a DANIELL'S cell be taken as one volt, or 10^8 on the C. G. S. system of units, we have for the magnetizing force of 1 cell estimated in the manner explained above (Part VI., § 183), the value $4\pi \frac{1688 \times 10^8}{86 \times 3 \cdot 828 \times 10^9} = 6 \cdot 443$. But the strength of the magnetizing current of 1 cell was measured by a deflection on the scale of the battery galvanometer of about 130 divisions, or a little more than twelve times the amount of the magnetizing force of the earth. Hence we have in absolute measure, '5 as a rough

II.

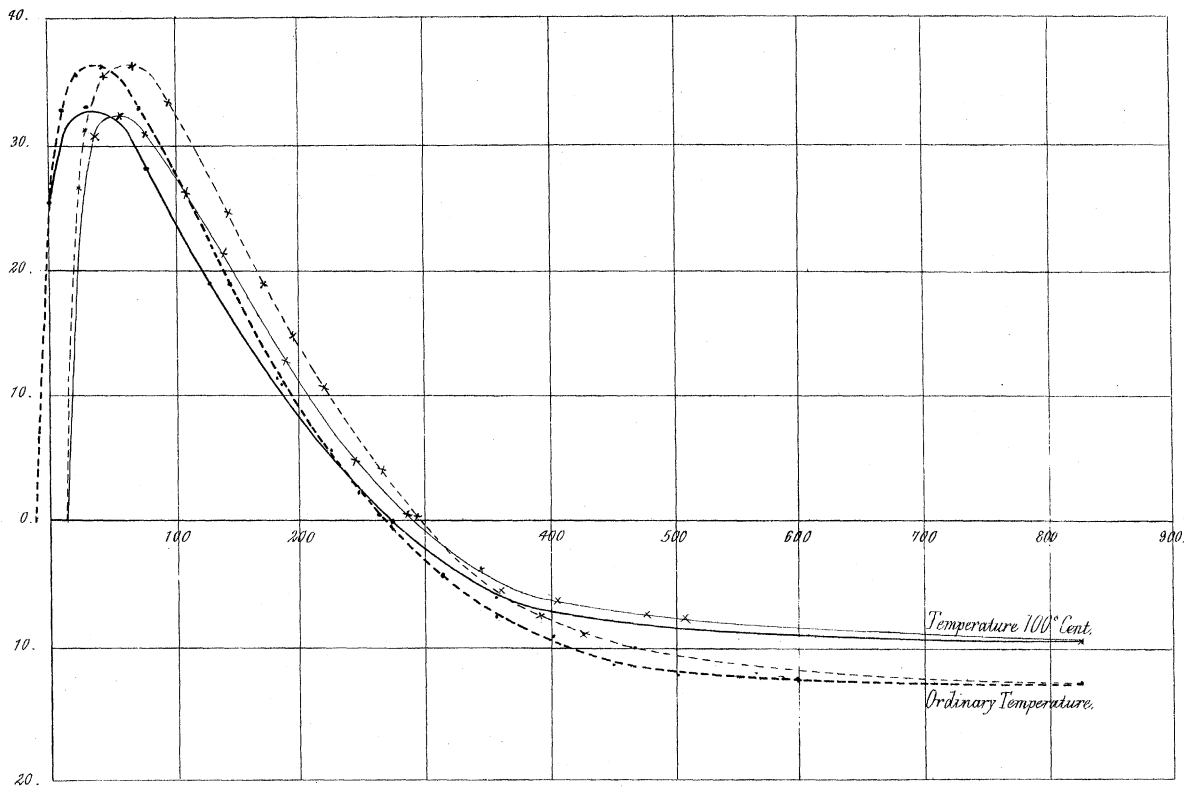

III.

Average curves for 14 lbs. "on and off."

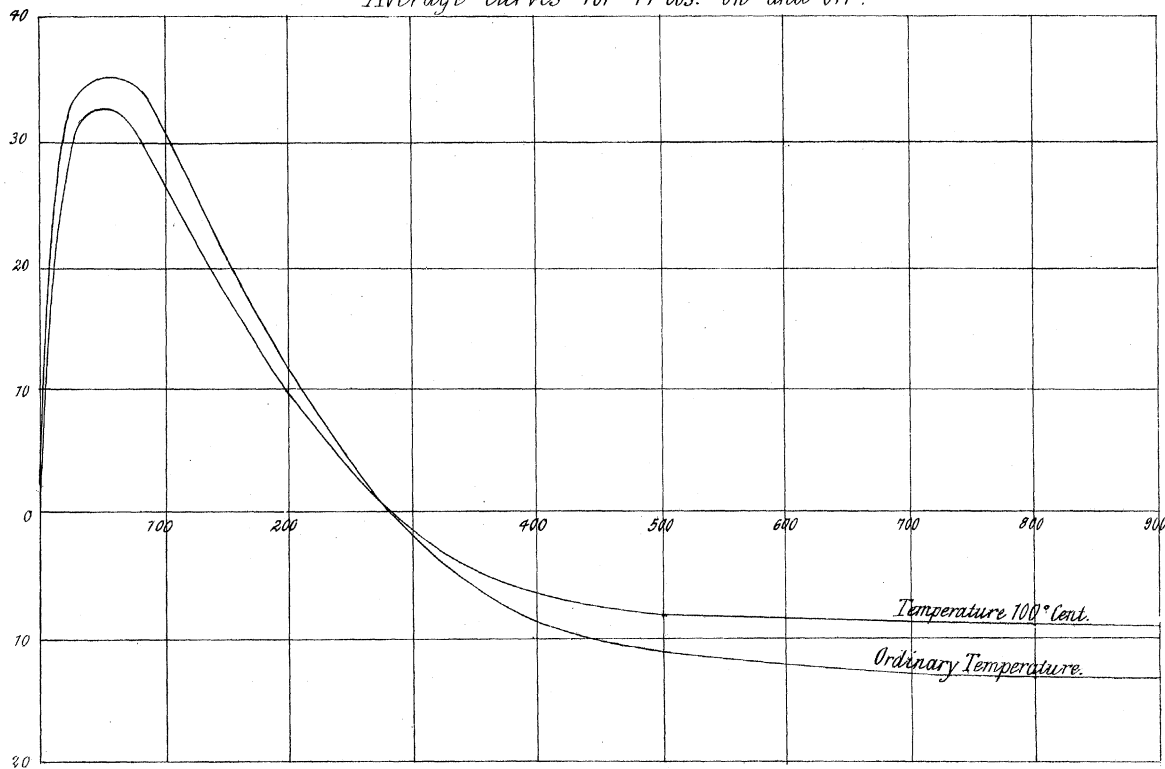

approximation to the value of the vertical component of the earth's magnetic force at Glasgow. The true value, as said above (Part VI., § 183), is nearly '43. (Compare also § 243 below.)

208. Immediately after the results given in Table I. were obtained, the experiments were repeated with the water in the cistern B kept constantly at the temperature of 100° C. Thus the water flowing through the channel between the coils may be considered as having been nearly at the boiling point. The results are given in Table II.

TABLE II.—Temperature 100° C.

Results for + M.			Results for - M.		
Operations.	Deflections.	Current strengths.	Operations.	Deflections.	Current strengths.
14 on	+26	0	14 on	0	11
„ off	-26		„ off	0	
„ on	+33	27	„ on	-31	34
„ off	-33		„ off	+31	
„ on	+28·5	75	„ on	-32·5	56
„ off	-28·5		„ off	+32·5	
„ on	+19	127	„ on	-31	86
„ off	-19		„ off	+31	
„ on	+11	185	„ on	-26·5	109
„ off	-11		„ off	+26·5	
„ on	+ 6	220	„ on	-22	138
„ off	- 6		„ off	+22	
„ on	0	274	„ on	-13	186
„ off	0		„ off	+13	
„ on	- 6	357	„ on	- 5	242
„ off	+ 6		„ off	+ 5	
„ on	- 8	453	„ on	- 0·75	283
„ off	+ 8		„ off	+ 0·75	
„ on	+ 9	830	„ on	+ 3	340
„ off	- 9		„ off	- 3	
			„ on	+ 6	406
			„ off	- 6	
			„ on	+ 7	478
			„ off	- 7	
			„ on	+ 7·5	508
			„ off	- 7·5	
			„ on	+ 9	830
			„ off	- 9	

209. For convenience of comparison, the results given in the above tables are represented graphically by the accompanying curves (Diagrams II. and III.), in which the abscissas represent magnetizing forces, and the ordinates augmentations and diminutions of the magnetism of the wire. In Diagram II., a separate curve is given for +M and -M, at both temperatures; the curves for the higher temperature being drawn in full lines, and those for the lower temperature in dotted lines. In their general features they are similar to the curves given in the preliminary notice above referred to; but they include a more exact determination of the amount of the magnetizing force which

gives maximum effect in each case, and of the points in which the curves cut the line of abscissas, and hence of the relation between the magnetizing force of the earth and the VILLARI critical value. The magnetizing force for which 14 lbs. "on" or "off" gave maximum effect was now found for the same wire to be about four or five times, and the VILLARI critical value about twenty-three times, the vertical component of the earth's magnetic force at Glasgow. These results also disprove the negative maximum indicated by the curves of that notice, and show (as there stated in the Note at the end) that for higher magnetizing forces than the VILLARI critical value, the effect approaches a constant amount and the curves become asymptotic.

210. The curves in Diagram III. were drawn by taking for ordinates the mean for each temperature of the effect for $+M$, and the effect for $-M$, of 14 lbs. "on" or "off," and for abscissas the corresponding current strengths, and therefore show approximately the effect which would have been produced by "on" or "off," had the wire not been affected by the magnetizing force of the earth.

By comparing the curve for cold water with the curve for hot water, we see that when the wire is at the temperature of 100° C., the average maximum effect of "on" or "off" is less than at the ordinary temperature of cold water by about 8 per cent. of the effect in the latter case, and that also, when the VILLARI critical value has been exceeded, the constant value to which the effect of "on" or "off" approaches is less for the higher temperature than for the lower, but in this case by about 30 per cent. of the amount of the effect for the lower temperature. The two curves also cross one another at a point above the line of abscissas, thus showing a greater critical value of the magnetizing force for the higher temperature than for the lower.

211. The curves of Diagrams IV. and V. give at both temperatures the average for each strength of magnetizing current of the effects on $+M$ and $-M$ of applying and removing stresses of 7 lbs. and 21 lbs. respectively.

A comparison of these curves with the average curves for 14 lbs. "on" and "off" (II. above) shows—

(1.) That the effect at both temperatures of the application and removal of the stress is greater with 14 lbs. than with 7 lbs., and much greater with 21 lbs. than with 14 lbs.; the maximums at the ordinary temperature in these three cases being respectively 31, 35, and 54.

(2.) That the VILLARI critical value is much greater for 7 lbs. "on" and "off" than for 14 lbs. : and, though by a smaller difference, greater for 21 lbs. than for 14 lbs.

(3.) The difference between the maximum effects of "on" or "off" for the high and low temperatures is greater for 7 lbs. than for either 14 lbs. or 21 lbs., and seems to be greater for 21 lbs. than for 14 lbs.

212. A series of observations of the effects of alternately making and breaking the circuit of the magnetizing coil and battery were made at both temperatures and for both $+M$ and $-M$. The method of procedure was as follows—

With no current flowing, a weight of 14 lbs. was placed in the scale-pan, and

IV.
Average Curves for 7 lbs. "on and off."

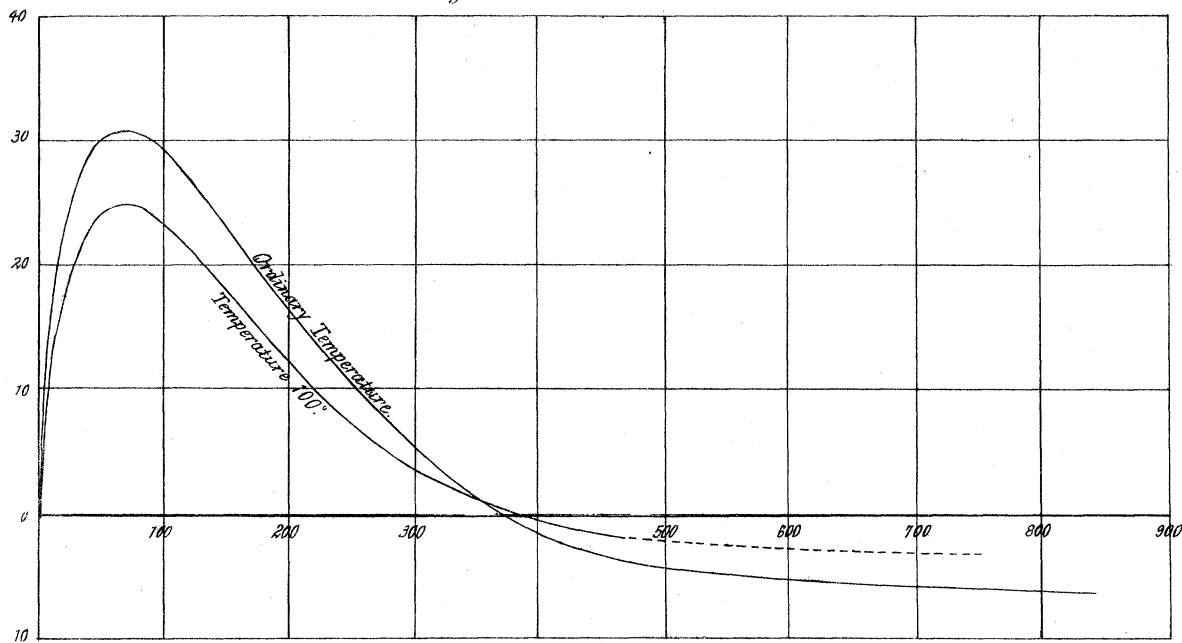

V.
Average Curves for 21 lbs. "on and off."

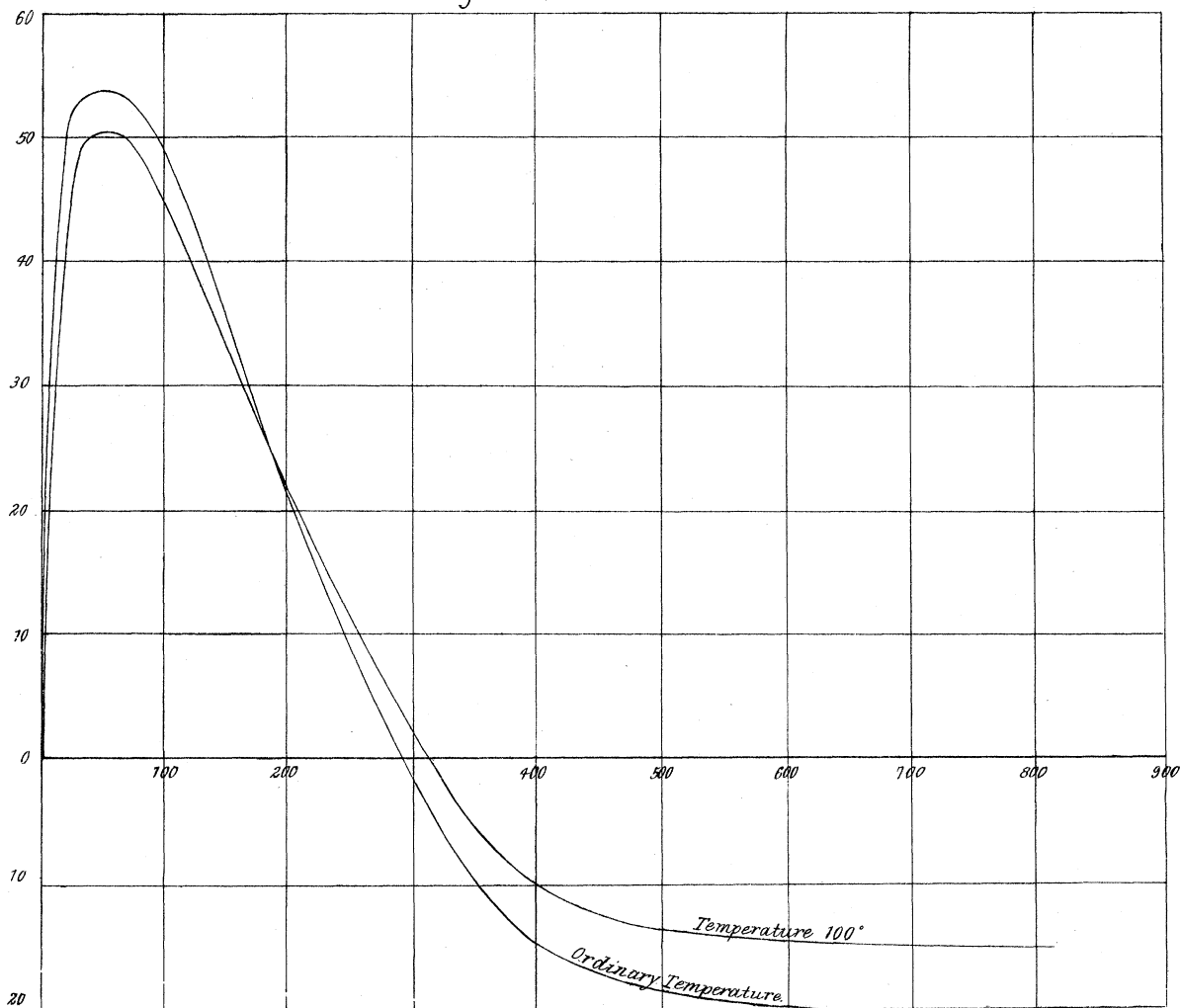

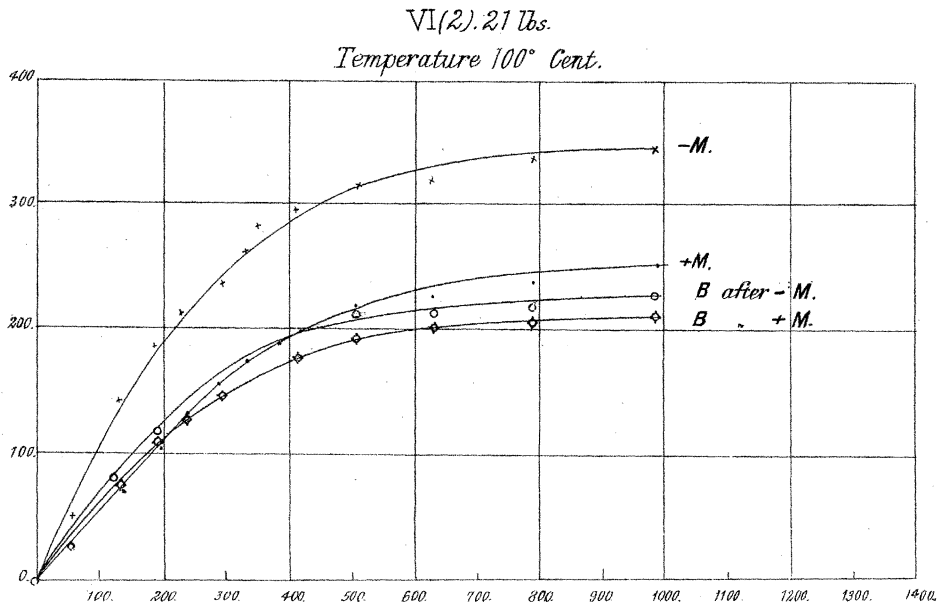
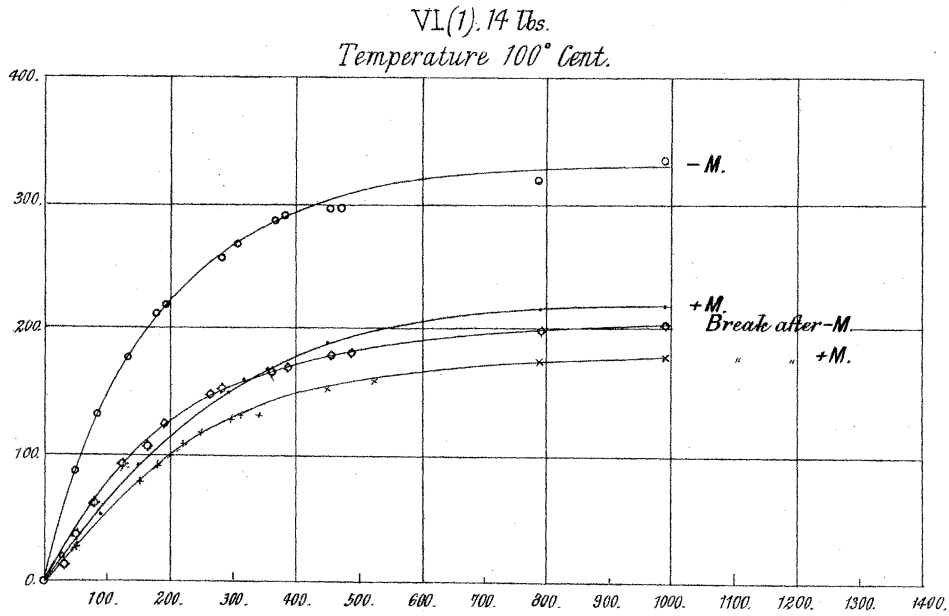
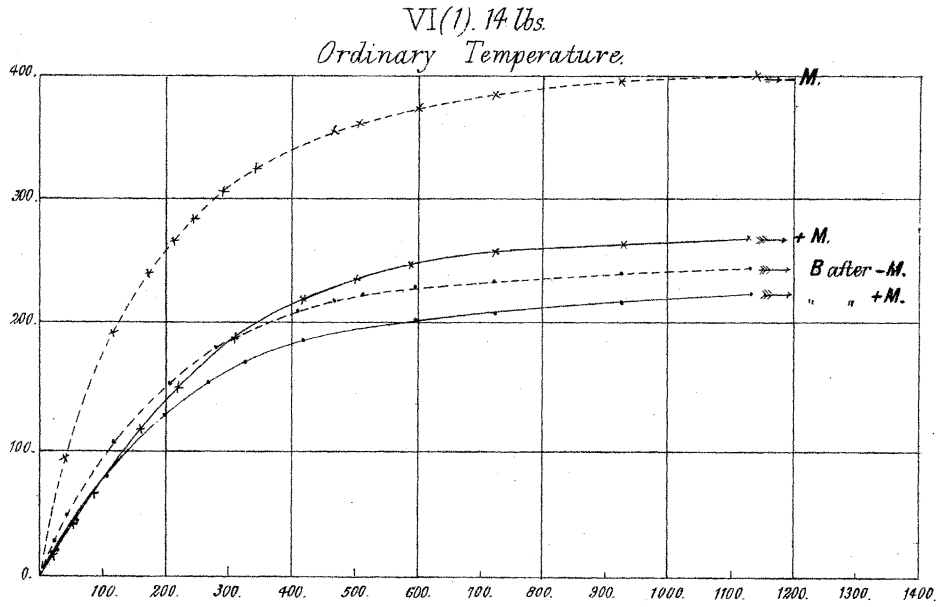

removed ten times in rapid succession, and the wire finally left with only the permanent weight of 1 lb. hanging on it. Then beginning with $+M$, a magnetizing current of small amount was applied, and the effect measured by the "throw" of the ballistic galvanometer. The weight of 14 lbs. was then applied and removed ten times in succession, the circuit broken with nothing but the permanent weight of 1 lb. hanging on the wire, and the deflection of the ballistic galvanometer again noted. The same cycle of operations was then repeated for higher and higher strengths of current until ten cells were placed in circuit with the magnetizing coil.

The same process was then followed with the $-M$.

These experiments were repeated also at both temperatures with 21 lbs. as the weight applied and removed ten times before each operation. Curves (1), of Diagrams VI., exhibit the results for 14 lbs., and curves (2) those for 21 lbs.

A very striking feature of these results is the great excess of the deflection produced by $-M$ over the deflection produced by $+M$. It cannot but be due to the terrestrially-induced magnetism existing in the wire each time before the current is made in either direction.

Comparing the results for the ordinary temperature with those for 100° C., we see that the effect at the higher temperature is always considerably less than at the lower temperature. Thus, taking the 21 lb. curves VI. (2), the deflection after $-M$ with the greatest magnetizing force is 320 for the lower temperature, and about 250, or 22 per cent. less, for the higher, and for the same magnetizing force the other deflections are less at the higher temperature than at the lower, in nearly the same proportion.

213. Immediately after the results for the temperature 100° C., shown in curves (2), had been obtained, an experiment was made to determine the amount by which (as stated in the Preliminary Notice of June 10, 1875, § 7) the effects of making and breaking the circuit of the magnetizing coil and battery when the wire is pulled exceed the effects of the same operations when the wire is free from pull. The process was the same as that described in § 212, except that after each ten "ons" and "offs" the weight of 21 lbs. was put on and left in the scale-pan and the circuit made or broken before it was again removed. The experiment was made at only one temperature, 100° C. The results are given in the curves VI. (3).

A full examination of the results shown in these Diagrams VI. (1), (2), (3), must be reserved for a later communication; and further experiments will be necessary to elucidate them. Meantime it is interesting to see by comparing the curves of VI. (3) with the curves of VI. (2) for the same temperature (100°), that the effect of the $-M$ is greater with the pulled than with the unpulled wire for every degree of magnetizing force; while the effect of the $+M$ is greater in the pulled wire for magnetizing forces less than 250, and greater in the unpulled wire for magnetizing forces exceeding 250. This was to be expected from the previously proved (§§ 209, 210) greater magnetic susceptibility in the pulled than in the unpulled wire, when the

magnetizing force is less than a critical value of 280 or 290 ; and greater susceptibility in the unpulled than in the pulled wire when the magnetizing force exceeds the critical value ; and from the fact that the difference in one direction of the susceptibilities in the pulled and the unpulled wire when the magnetizing force is the Glasgow vertical force, is about three times as much as the difference in the other direction when the magnetizing force is 80 times the Glasgow vertical force. The effect of the $-M$ includes a reversal of the natural vertical force. That of the $+M$ is merely an addition to it.

§§ 214–222. *Preliminary investigation by the direct Magnetometric Method of the effects of transverse stress on the Magnetization of an Iron Tube.*

214. In order to test qualitatively, in the first instance, the effects of transverse stress on the magnetization of iron, experiments were made on a smooth gun-barrel, said to be made of tolerably soft iron. The barrel was fitted at its muzzle with a piston working watertightly in a Bramah stuffing-box, and served round with a magnetizing coil of silk-covered copper wire, separated from the barrel by a copper tube, and containing within it an induction coil, in order that the ballistic method might be used if this was deemed advisable. The barrel was then fixed rigidly to a stone pier in the laboratory, with its breech end resting on a large block of stone which formed the base of the pier. On a shelf, also attached to the pier, and at a convenient distance due magnetic west of the barrel's axis, a small reflecting magnetometer was placed, with its needle on a level with the top of the barrel. A dead-beat galvanometer, the resistance of which was only a small fraction of an ohm, was used to measure the magnetizing current. The barrel having been filled with water was subjected to hydrostatic pressure, applied by means of a lever carrying a weight, the lever itself being counterpoised by a weight attached to a cord passing over a pulley above. The pressure (the friction of the piston in its collar being neglected) was measured by the amount of the applied weight and the multiplication of the lever. The effects of the application and removal of the pressure were measured by the deflections of the galvanometer needle, read on a scale of half millimetres, placed at a distance of one metre from the mirror.

215. The first experiments after the apparatus had been got into working order brought out the remarkable result that the effects of transverse stress on the magnetization of iron are, as to quality, the opposite of those of longitudinal stress ; that is to say, when the magnetizing force is less than a certain critical value, the effect of applying transverse stress is to diminish, and of removing it to increase, the induced magnetization ; and when this critical value has been exceeded, the effect of the application of transverse stress is to increase, and of its removal to diminish the induced magnetization.

The curves (1) of Diagram VII. show (after the manner of Diagram II. above) the effect for both $+M$ and $-M$ on the magnetometer needle, when placed on a level

VI(2). 21 lbs.
Ordinary Temperature.

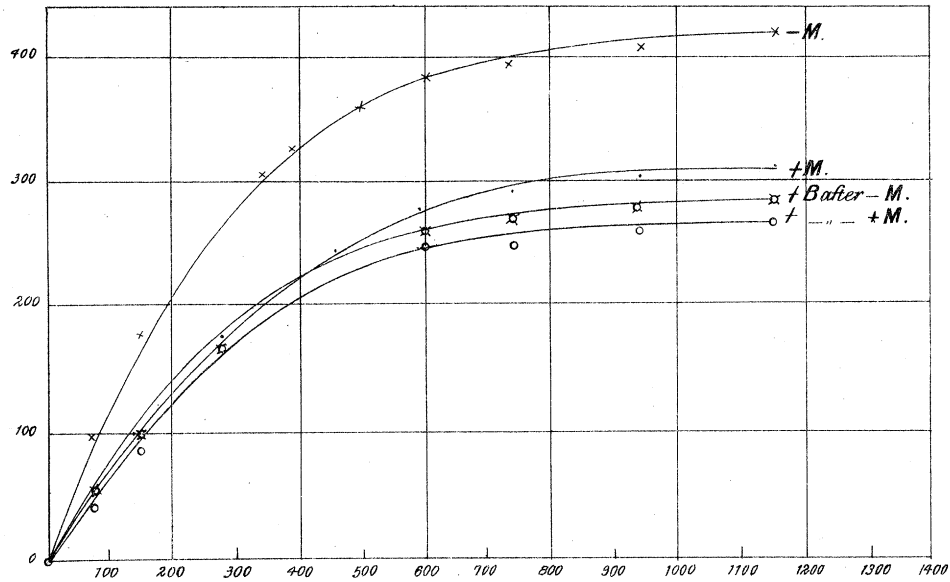

(3)

Temperature 100° Cent. M & B with 21 lbs. on.

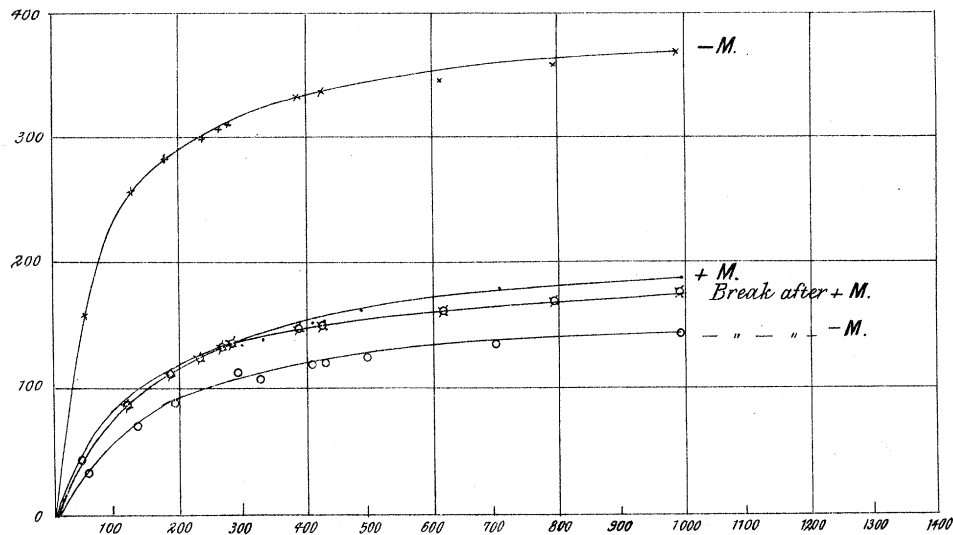

VII.
(1)

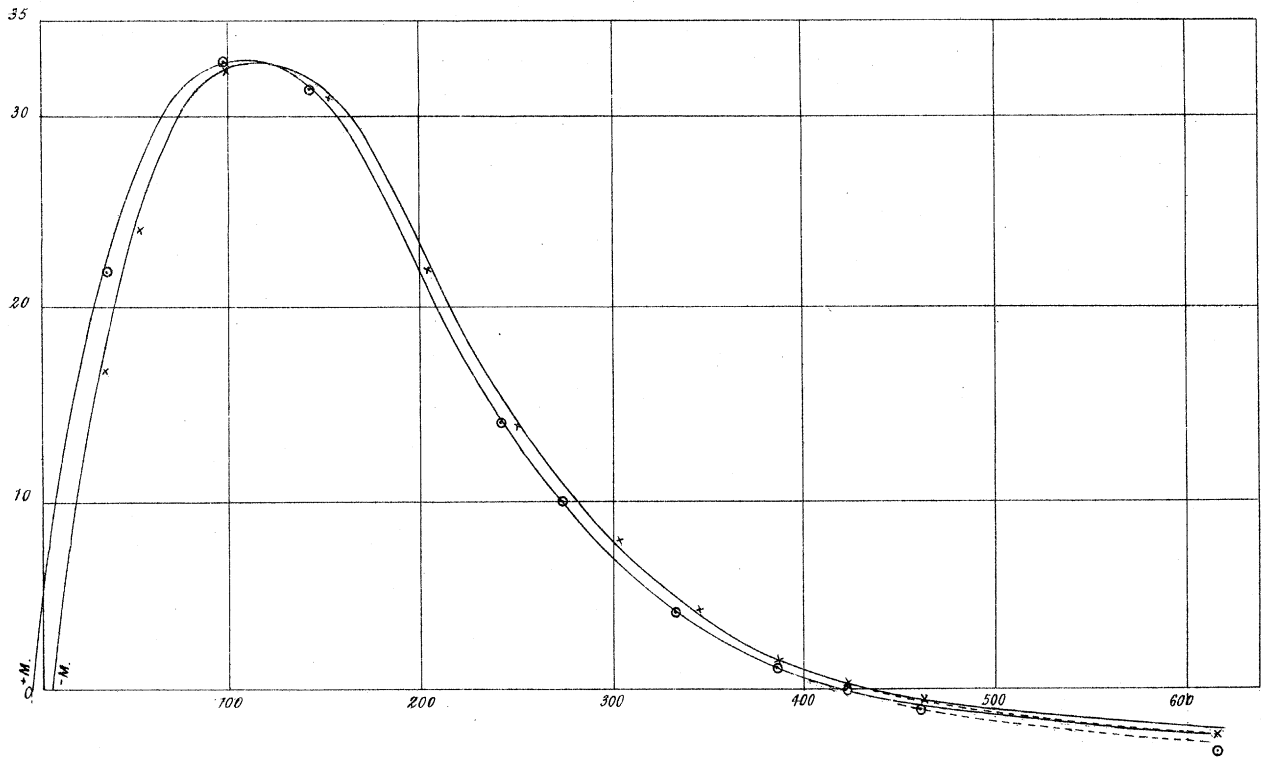

(2)

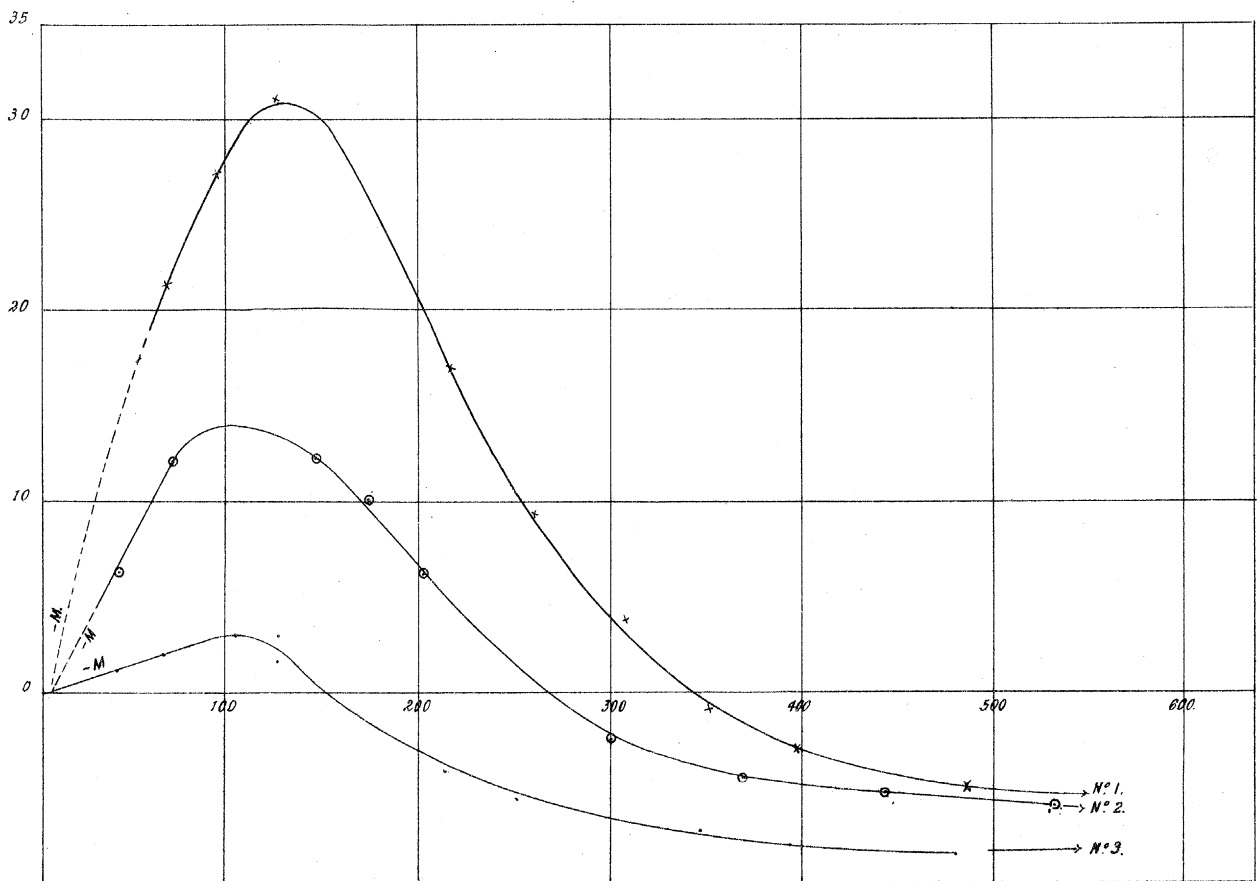

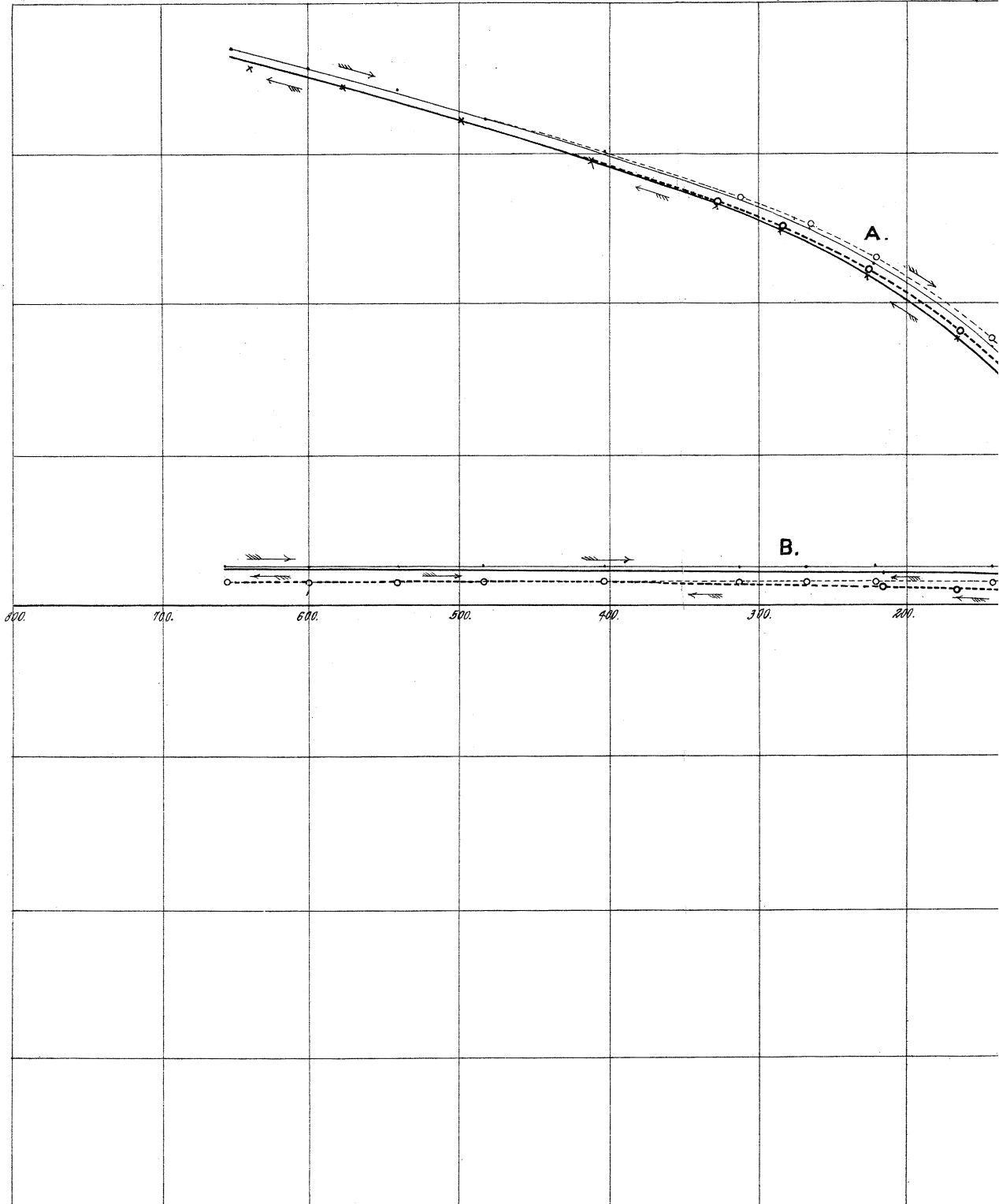

VIII.

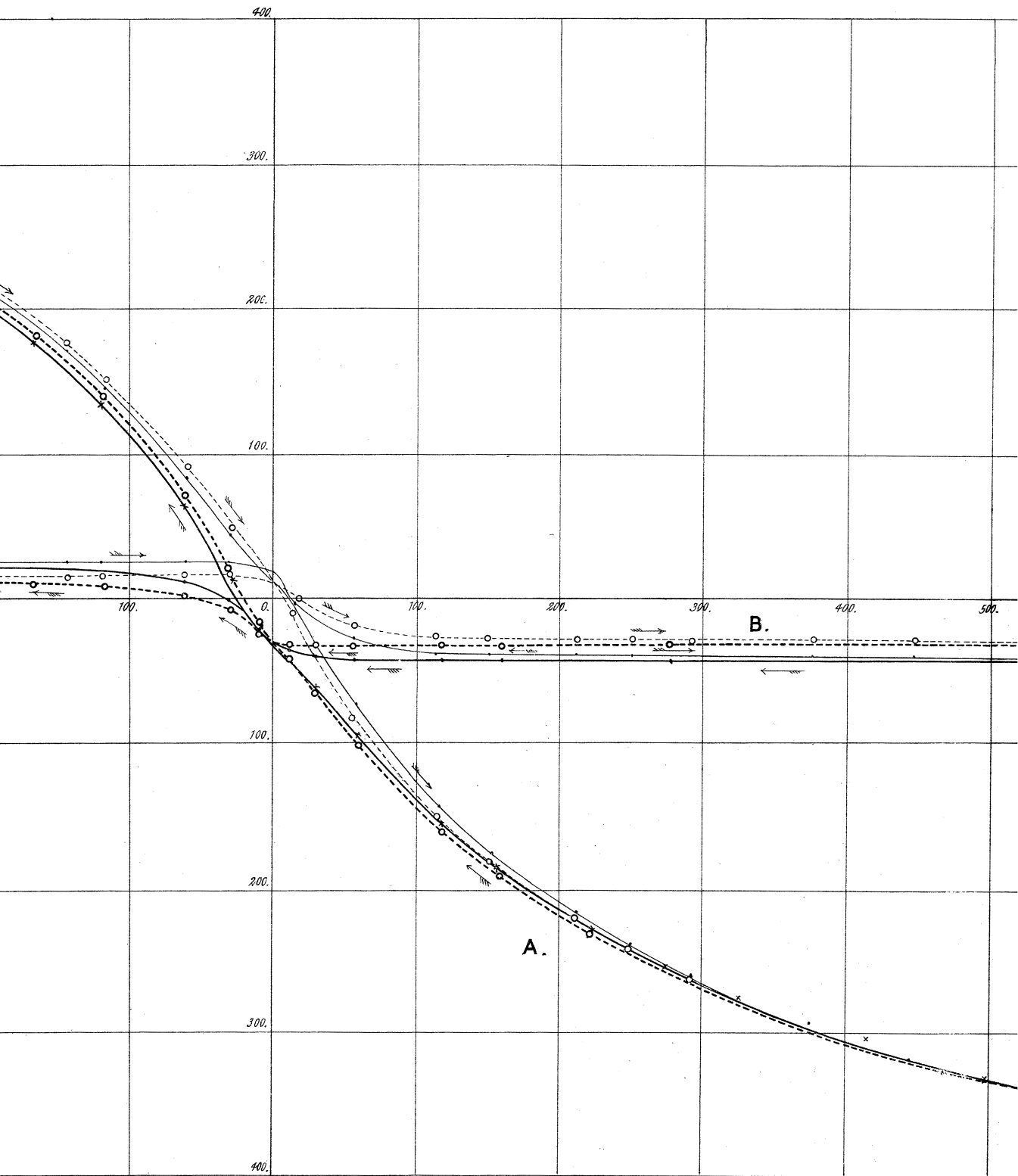

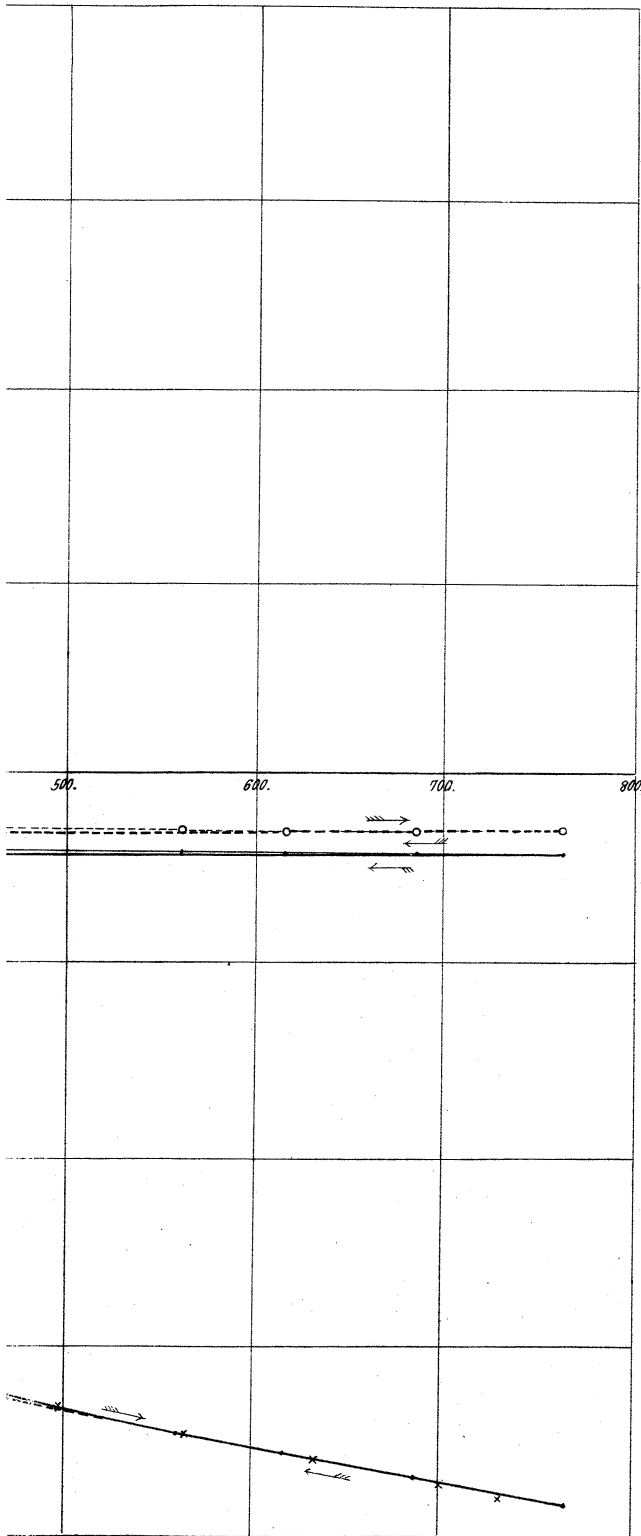

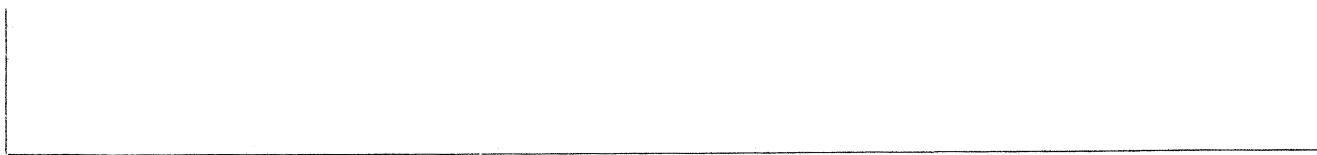

Harrison & Sons, Lith. S^t. Martins Lane, W.C.

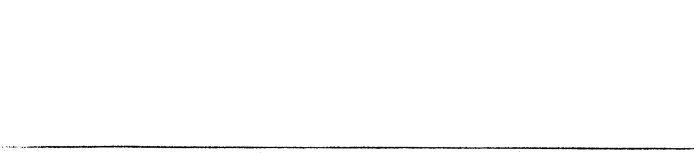

with the top of the barrel, produced by applying a transverse outward pressure of (approximately) 1000 lbs. per square inch to the iron of the barrel. The ordinates are given in divisions of the magnetometer scale, and the abscissas in divisions of the scale of the battery galvanometer. It is interesting to note that the critical value of the magnetism is for this position of the magnetometer nearly 80 times the vertical component of the earth's magnetic force at Glasgow.

216. By placing the magnetometer at lower levels relatively to the barrel, it was found that the values of the current required for maximum and for zero effect, by "on" and "off," were less the nearer the level of the magnetometer needle was to the middle of the length of the bar. The following table shows the principal effects for $-M$ at four different levels of the magnetometer needle:—

Distance* of top of barrel above level of magnetometer needle.	Maximum deflection before critical value was reached.	Magnetizing current for maximum deflection.	Critical value of magnetizing current.
Centims.			
0	32·8	110	430
10·5	31	130	345
21·0	14	100	265
31·5	3	100	147

The whole of the results for the $-M$ in the last three cases are given in curves (2) of Diagram VII.

217. The magnetometer needle was placed on a level with the top of the barrel, and at a distance of two metres from its axis. Experiments were then made to find the total magnetization produced by different strengths of magnetizing current, and the effects on it of ten successive applications and removals, while the current was still flowing, of a hydrostatic pressure of 1000 lbs. per square inch; also to find the total residual magnetism after the removal of the magnetizing current, when the tube was left solely under the influence of the earth's vertical magnetic force, and the effect on it of ten successive applications and removals of the same hydrostatic pressure, while the bar was still under this magnetizing influence. The general character of the results of these experiments is difficult to describe in words, but can be seen by inspecting Diagram VIII., in which the curves marked A show the total magnetization, those marked B the residual magnetization. The abscissas of these curves are proportional to the magnetizing forces and the ordinates to the observed magnetization: but they have inadvertently been so drawn that their negative ordinates show magnetization of the same polarity to that produced by the inductive influence of the earth's vertical force, and their positive ordinates magnetization of the opposite polarity. The full lines in each set of curves show the magnetization before, the dotted lines after, ten "ons" a "offs" of and pressure of 1000 lbs. per square inch.

* The length of the barrel and of the magnetizing coil was about 90 centims.

The results in these experiments were obtained by beginning with a *negative* (*i.e.*, opposed to magnetizing force of earth) magnetizing current of about 700 divisions of the battery galvanometer scale, which was gradually diminished to zero and then increased until a *positive* current of 700 (20 cells) divisions was reached. This process was then exactly reversed. The results may be examined in the order in which they were obtained, by beginning at the left hand ends of the curves A and B, and passing to the right along the thinner lines, returning to the left along the thicker lines.

218. The magnetometer was found in this position to be at too great a distance from the barrel to show the residual magnetism with accuracy, and accordingly its distance from the barrel was reduced to one metre, and the effects of residual magnetism alone observed. These are shown by curves marked B' of Diagram VIII'. The method and order of experimenting were here the same as described in § 217; and the explanation of Diagram VIII., curves B, applies also to Diagram VIII', except that in the latter the directions of the ordinates are reversed from the former; thus in VIII' positive ordinates indicate positive magnetization, negative ordinates negative magnetization (see § 205).

219. Beginning at the extreme left of curves marked B' on Diagram VIII', and following the arrows, it will be seen that the residual magnetism remains nearly constant in amount until the magnetizing current has been diminished to about 300 divisions, when it begins to take a greater negative value, and continues to do so until the current is brought down to 50 divisions, when it begins slowly to diminish. After the reversal of the current the full residual magnetism diminishes with great rapidity, passing through zero at about 15 divisions of positive current. It then becomes positive, preserving nearly the same rapidity of change for some distance beyond zero. After a positive current of 150 divisions is reached, the full residual magnetism increases very slowly, and the curve becomes asymptotic towards a value of about 440. The curve showing the residual magnetism after ten "ons" and "offs" has similar characteristics to those for the full residual magnetism; the increase on the left side of zero at about 300 divisions of negative current is, however, more decided.

The general character of the return curves is similar to that just described. It is to be remarked, however, that the zero of current in each of them is much further passed before the zero of magnetization is reached. This difference between the going and returning curves would be done away with, and the curves from left to right and right to left in the diagram would be perfectly symmetrical about the zero of magnetizing current, if the influence of the earth's magnetic force were eliminated. I intend to return to this subject with a modification of the experimental arrangements, to allow the residual magnetism to be observed unaffected by any influence due to magnetizing force in the direction of the length of the tube; instead of as here with the tube always under the magnetizing action of the vertical component of the earth's magnetic force, when the electro-magnetic current is not flowing.

The curves, except in the positions corresponding to zero of current, show that the

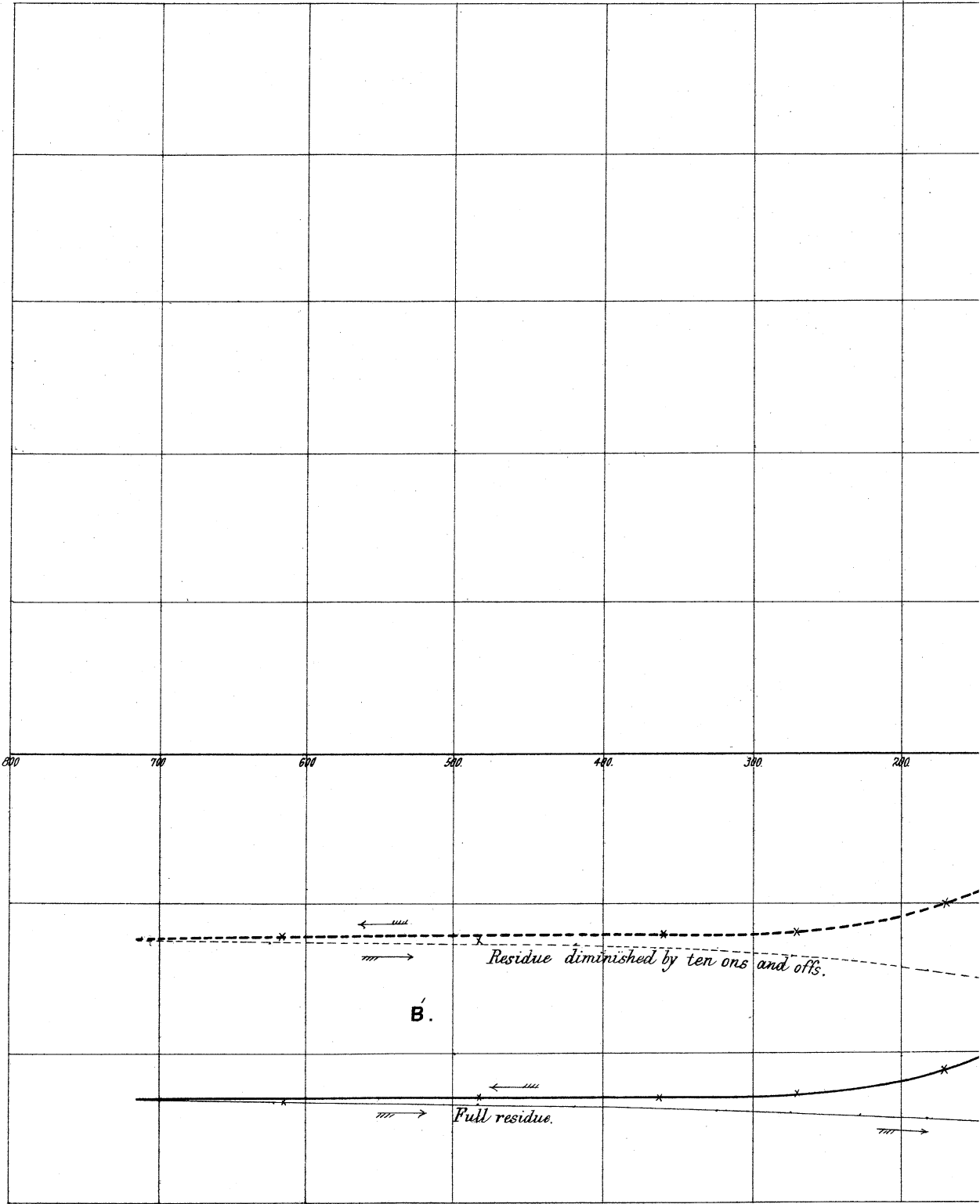

VIII.

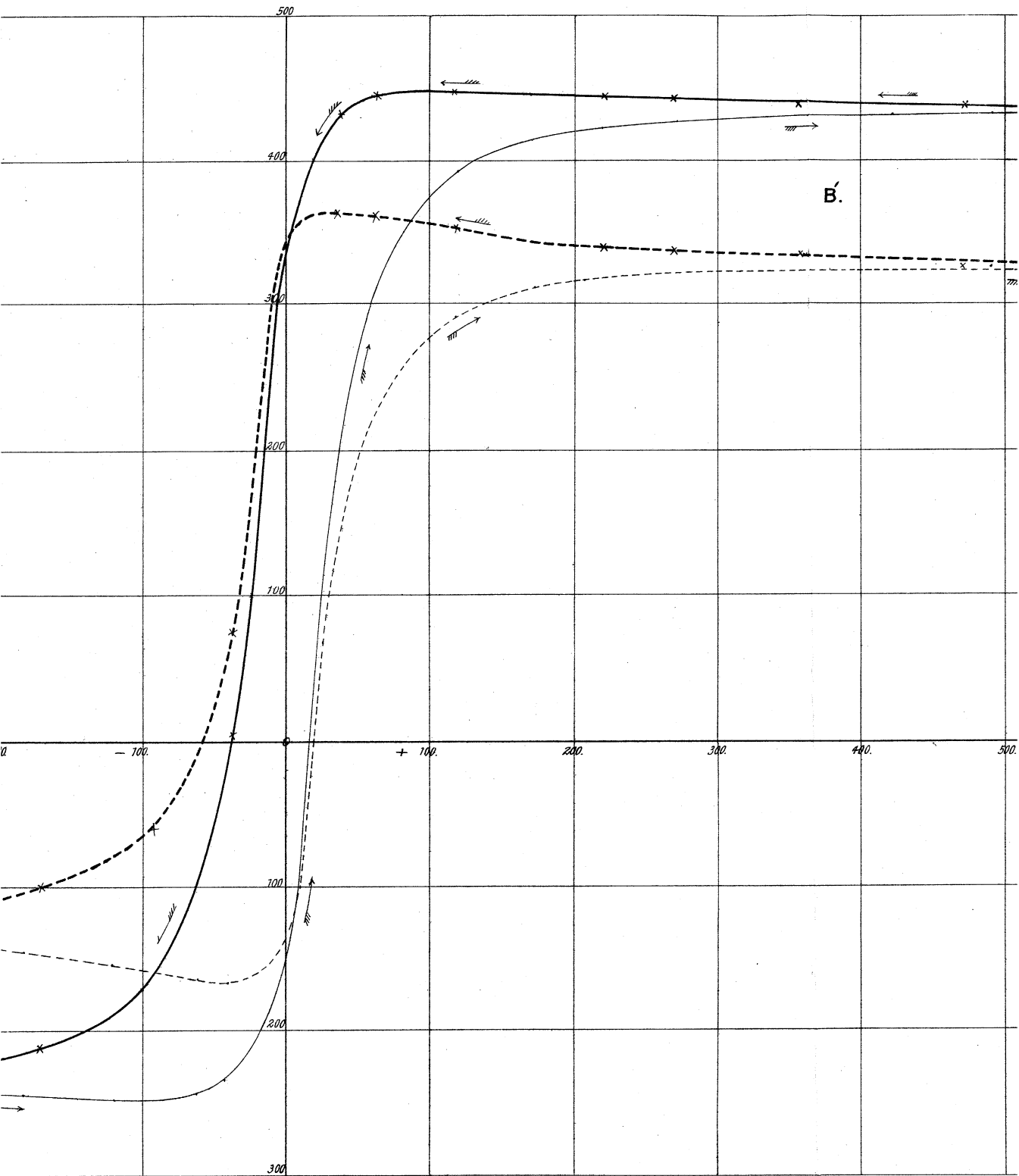

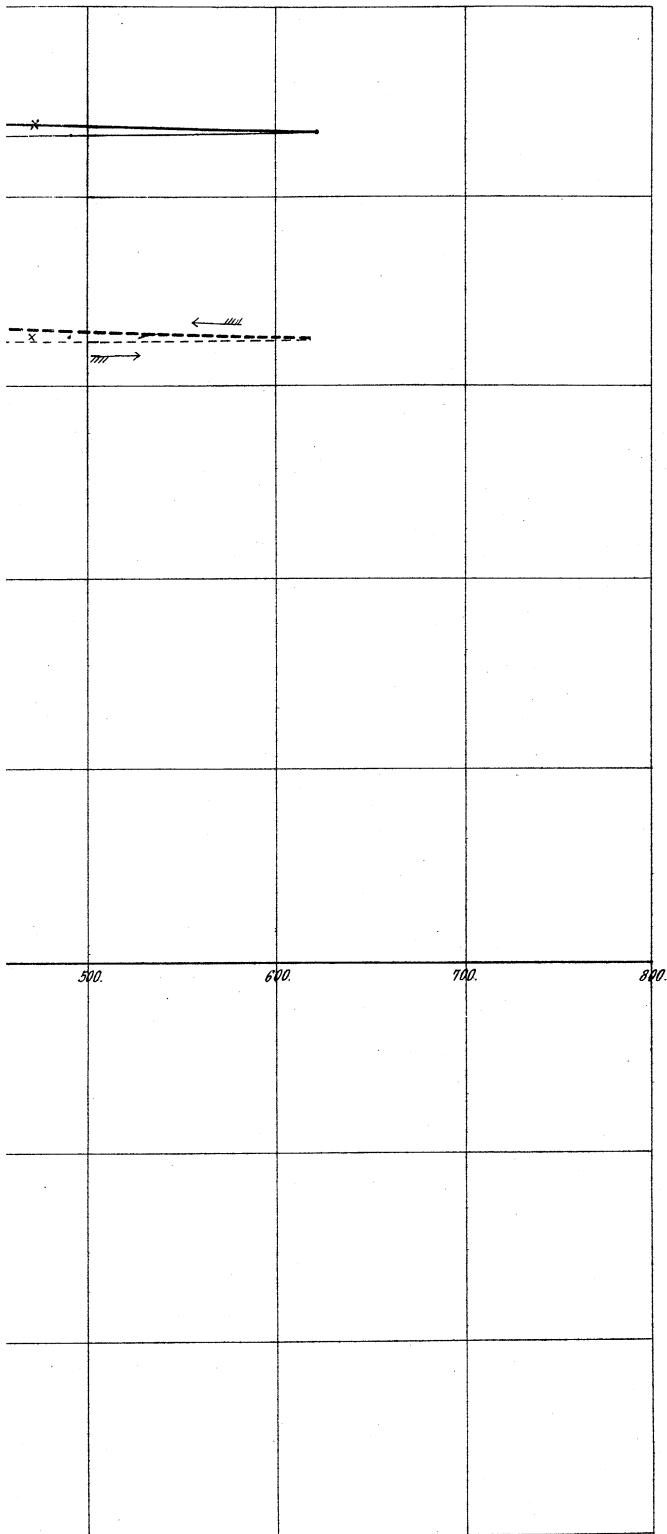

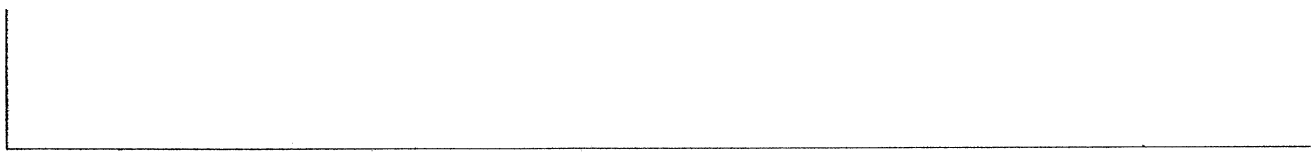

Harrison & Sons. Lith. St. Martins Lane W.C.

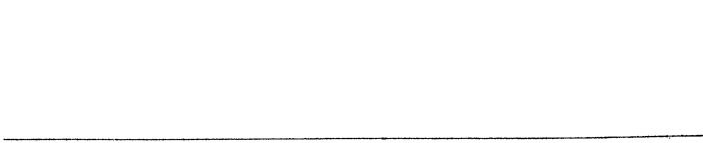

ten "ons" and "offs" were not sufficient to shake out the effect of the powerful magnetizing force of the current, and allow the barrel to take the magnetization due to the vertical component of the terrestrial magnetic force. Indeed, they only diminished the residual magnetism in the curves both from left to right and from right to left by about 100 divisions, out of total residuals from 230 to 440. It is interesting to see by contrasting the right hand ends of the curves with the left hand ends, how much stronger the residual magnetism is when helped, than when opposed by the vertical magnetic force of the earth.

220. Comparison between the results of the effects of longitudinal and transverse pull shows that an aeolotropic property of different magnetic inductive susceptibility in different directions is temporarily developed in soft iron by aeolotropic stress (that is to say by stress not consisting of positive or negative pressure equal in all directions). The results show that with low magnetizing forces, negative pressure perpendicular to one set of parallel planes of soft iron produces an augmentation of magnetic susceptibility in the direction of the pressure and diminution of the susceptibility in all directions at right angles to it. The effects of positive pressure have not yet been tested experimentally, but it is certain that they will be opposite to the effects of negative pressure. Independently of experiment, we may also infer that the effects of infinitely small positive pressure perpendicular to one set of parallel planes, and infinitely small negative pressure of equal amount perpendicular to a set of parallel planes at right angles to them, must be equal and opposite in the directions of these pressures, and therefore must leave the magnetic susceptibility unaltered in the directions inclined 45° to them. This is exactly the stress which is experienced in a twisted wire of circular section; the amount of the stress being zero in the axis of the wire, and being elsewhere in simple proportion to distance from the axis. The directions of the positive and negative pressures at any point of the substance are two lines in the tangent plane of the cylindric surface through it, co-axial with the boundary of the wire, and inclined at 45° to the normal plane section. Hence, when the torsion is infinitely small, the magnetic susceptibility of the wire in the direction of its length must be unaltered, and if finite amounts of torsion produce any change in the magnetic susceptibility, the amount of this change must ultimately (for very small torsions) vary inversely as the square of the amount of torsion, as we see by remarking that whatever effect is produced must be independent of the direction of the torsion, there being nothing of helicoidal quality in longitudinal magnetization.

221. In WIEDEMANN'S 'Galvanismus' (vol. II., §§ 476-498) an abstract is given of researches in this subject by MATTEUCCI, WERTHEIM and EDMUND BECQUEREL.* One main result of all these investigations is that torsion in either direction diminishes the temporary inductive longitudinal magnetization of soft iron.

222. Nearly two years ago I instituted a series of experiments on the subject

* MATTEUCCI, 'Comptes Rendus,' t. xxiv., 1847; WERTHEIM 'Comptes Rendus,' t. xxxv., p. 702, 1852.

chiefly for the purpose of finding the influence of torsion upon the longitudinal magnetization of soft iron wire subjected to different amounts of pulling force. These experiments, in which the magnetizing influence was simply the vertical component of the earth's magnetic force, were carried out by Mr. DONALD MACFARLANE. The mode of experimenting and the results obtained are described in the following report.

§§ 223–229. *Experiments on the effect of torsion and stretching in altering the induced Magnetism of a very soft Iron Wire, subjected to various amounts of constant pull.*

223.—*Description of Apparatus.*—In the Diagram IX. (facing § 201 above) AB is a soft iron wire, gauge No. 22, 81 centims. long, to the ends of which were soldered pieces of No. 16 copper wire; the upper piece, AD, about 5 metres in length, was attached to the ceiling of the room with an arrangement for raising or lowering it through a small space, the lower piece, BC, about 50 centims., had attached to its lower end a scale-pan for holding the stretching weight.

E is a small mirror magnetometer, the mirror being 1 centim. diameter, carrying a magnet 8 millims. in length and suspended at N by a single silk fibre 10 centims. long; and I a lens close to the mirror; F is a paraffin lamp; and GH a scale (bent into a circular arc of which E is the centre), on which is formed the image of a fine wire placed in front of the lamp flame, at E.

L and M are two edges at right angles to one another, fixed to the stand carrying the magnetometer, and just in contact with the wire: their use is to make sure that the wire is maintained in the same position relatively to the centre of the magnet.

K is an arm soldered to the copper wire, BC, for applying torsion to the wire, and immediately below it is a circle divided at intervals of $45^{\circ} 20'$, with small holes at each division for inserting pegs to keep the arm twisted at any angle while readings are being taken.

A similar arm was soldered to the copper wire AD at O, the two ends of which were in contact with two vertical guides, thus confining the twist to the portion of wire between K and O.

The distance of the wire from the centre of the magnetometer needle was 8.2 centims.; distance of scale from mirror, 157 centims.; one division of scale 0.5 millim.

The experiments represented in the Diagrams No. X. to No. XXIX. were made in this way:—

Having removed the wire to a distance from the magnetometer, the zero reading of the latter was taken; the wire was placed in position, a stretching weight put in the scale-pan, and the reading on the torsion-circle noted when the wire was free from torsive stress; torsion was then applied by turning the lower end of the wire 20° at a time up to 320° , and the reading on the magnetometer scale at each step taken.

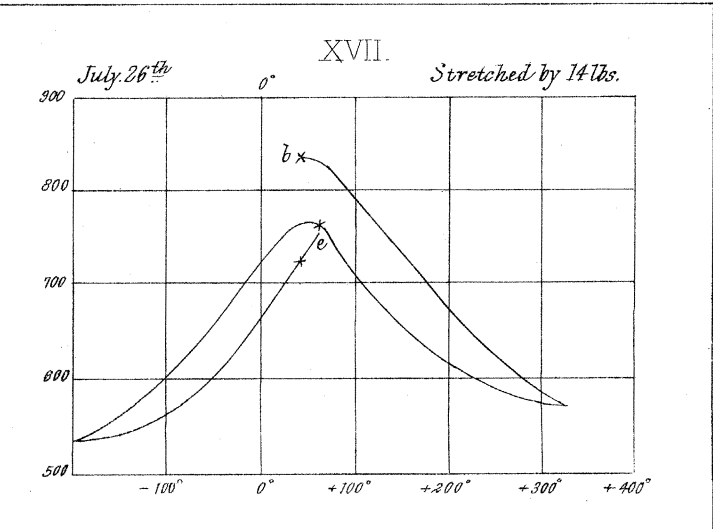
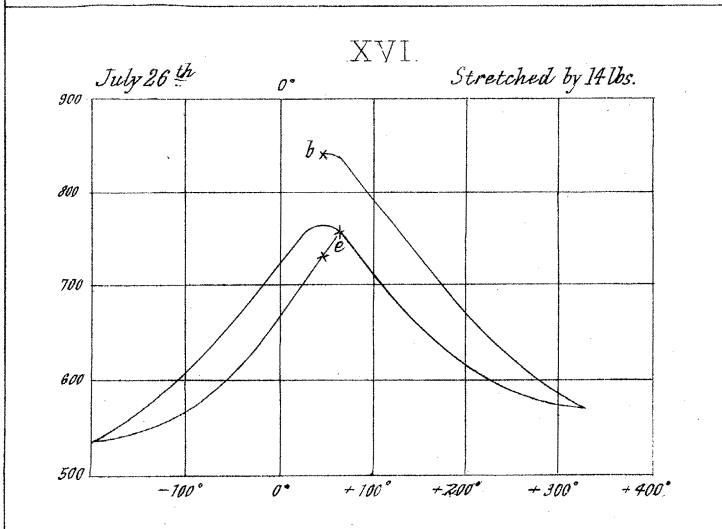
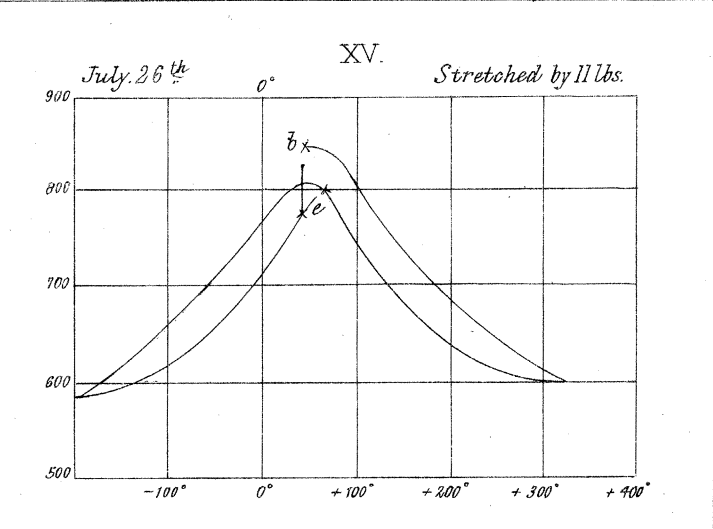
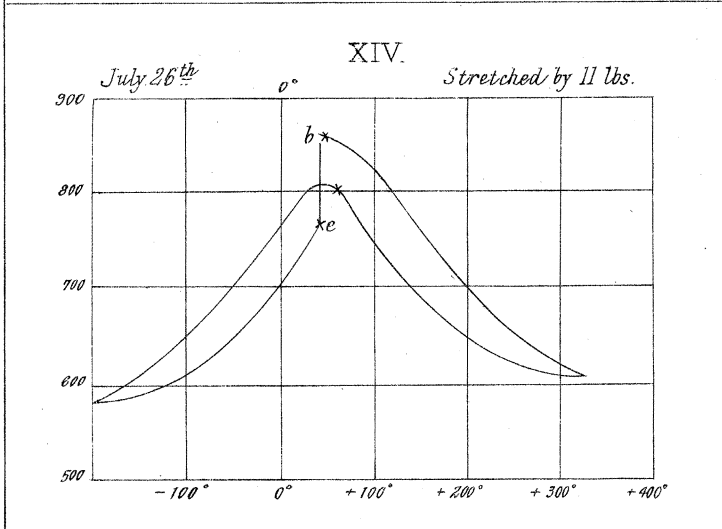
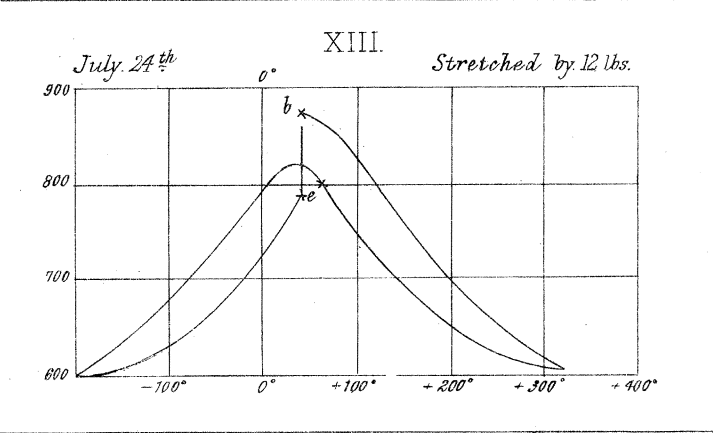
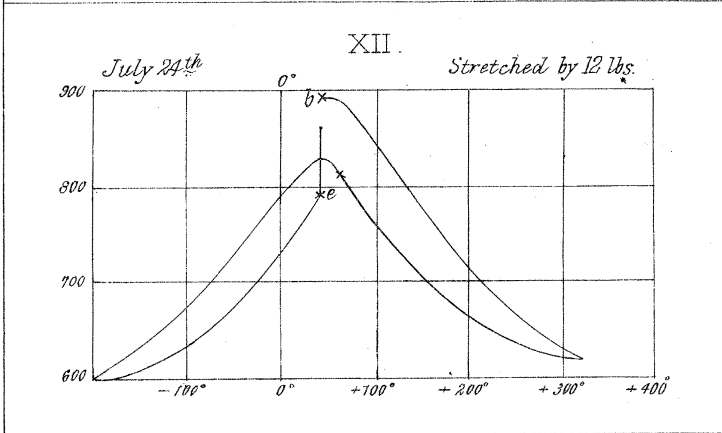
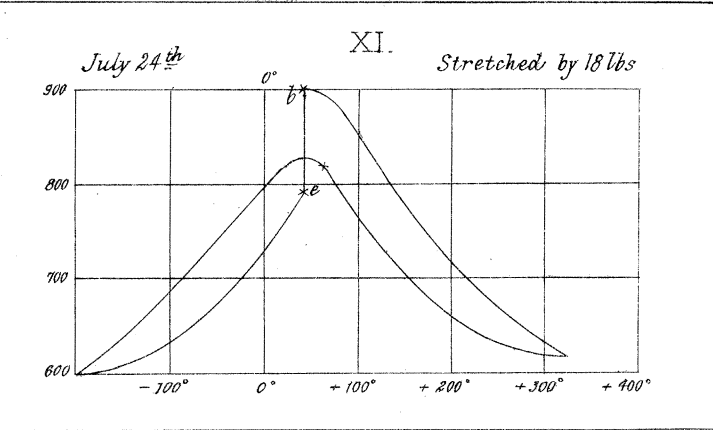
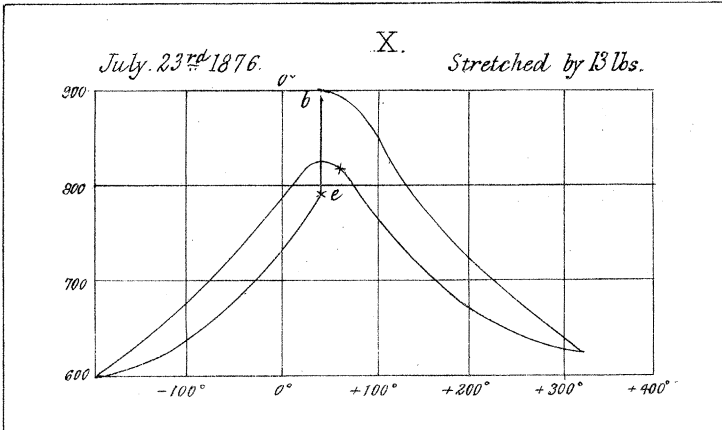

Similarly, readings of the deflection were taken as the torsion was taken out, and then continued in the opposite direction as far as -200° and back to the original starting point. At the end of each of the first seven series the weight was taken off and put on again.

The results are represented in the accompanying diagrams of curves Nos. X. to XXIX. In each diagram the numbers at the side indicate the readings on the magnetometer scale, and those at the bottom the readings on the torsion circle, a cross (\times) marks the positions where the couple of torsion was zero, *b* the beginning, and *e* the end of each experiment.

224. Explanatory remarks.

Diagram X.

Time, July 23, 4^h 12^m to 5^h 25^m.

Zero of magnetometer, 90 divisions.

Stretching weight, 13 lbs.

Weight off and put on, final reading rose from 790 to 895.

Diagram XI.

July 24, 11^h 0^m to 11^h 55^m.

Stretching weight, 13 lbs. left on from last.

Zero of magnetometer at end, 85.

Weight off and on, final reading rose from 815 to 896.

Diagram XII.

Time, July 24, 12^h 20^m to 1^h 5^m.

Stretching weight, 12 lbs.

Zero of magnetometer, beginning 85, end 85.

Weight off and on, final reading rose from 820 to 874.

Diagram XIII.

Time, July 24, 1^h 15^m to 2^h 0^m.

Stretching weight, 12 lbs.

Zero of magnetometer, beginning 85, end 90.

Weight off and on, final reading rose from 813 to 876.

Diagram XIV.

July 26, 12^h 50^m to 1^h 35^m.

Stretching weight, 11 lbs. on for 46 hours.

Zero of magnetometer, at end 95.

Weight off and on, final reading rose from 800 to 850.

Diagram XV.

July 26, 1^h 45^m to 2^h 25^m.

Stretching weight, 11 lbs.

Zero of magnetometer, at beginning 95, end 100.

Weight off and on, final reading rose from 803 to 835.

Diagram XVI.

July 26, 4^h 20^m to 5^h 10^m.

Stretching weight, 14 lbs.

Zero of magnetometer, at beginning 100, at end 100.

Weight off and on, final reading rose from 750 to 830.

Diagram XVII.

July 26, 5^h 20^m to 6^h 10^m.

Stretching weight, 14 lbs.

Zero of magnetometer, at beginning 100, at end 100.

Diagram XVIII.

July 28, 1^h 25^m to 2^h 15^m.

Stretching weight, 9 lbs.

Zero of magnetometer, at beginning 100.

Diagram XIX.

July 28, 4^h 45^m to 5^h 35^m.

Stretching weight, 9 lbs. left on from end of No. IX.

Zero of magnetometer, at end 105.

Diagram XX.

July 28, 5^h 20^m to 6^h 0^m.

Stretching weight, 10 lbs.

Zero of magnetometer, at beginning 105.

Diagram XXI.

July 30, 12^h 40^m to 1^h 20^m.

Stretching weight, 10 lbs. left on 42 hours from preceding No. XI.

Zero of magnetometer, at end 105.

Diagram XXII.

July 30, 4^h 20^m to 5^h 10^m.

Stretching weight, 16 lbs.

Zero of magnetometer, at beginning 105, at end 105.

Diagram XXIII.

July 30, 5^h 20^m to 6^h 10^m.

Stretching weight, 16 lbs.

Zero of magnetometer, at beginning 105, at end 105.

Note.—This experiment (XXIII.) was intended to be a continuation of the preceding. The magnetometer zero at the beginning was found, without taking off the weight, by drawing the wire aside; but the disturbance thus occasioned when the wire was replaced raised the final reading of No. XXII. from 690 to 712, the initial reading of No. XXIII.

The experiments represented in the six diagrams which follow were each repeated without stopping, and the repeat is represented by the dotted lines.

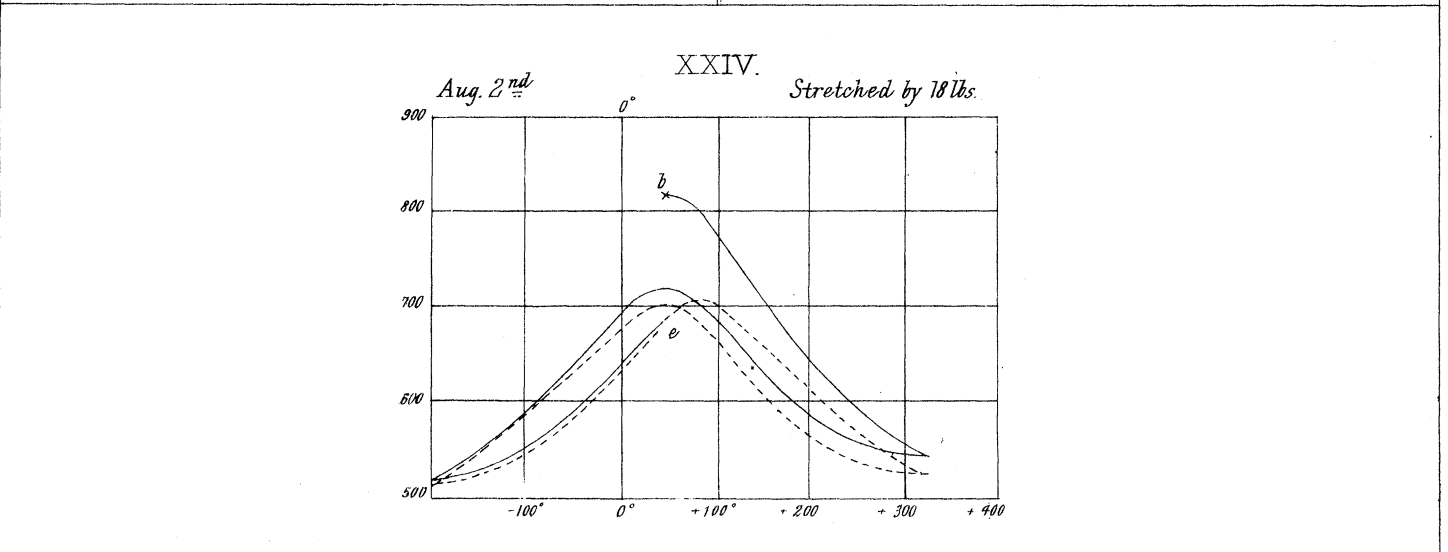
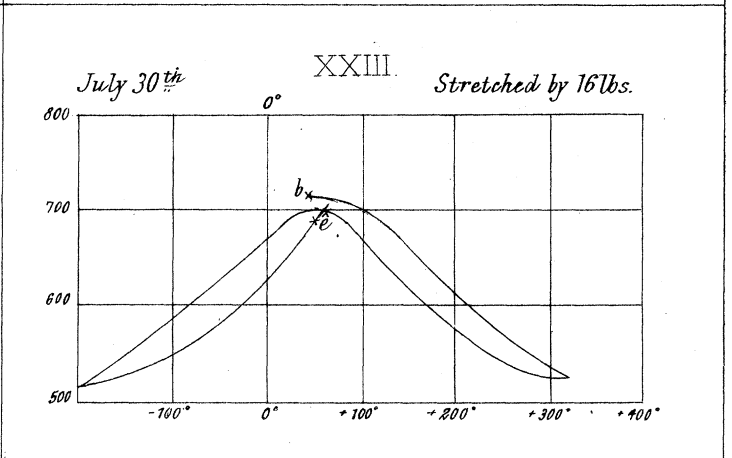
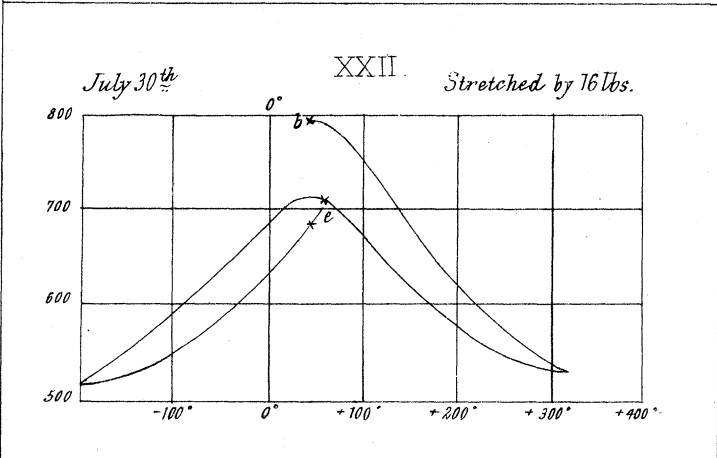
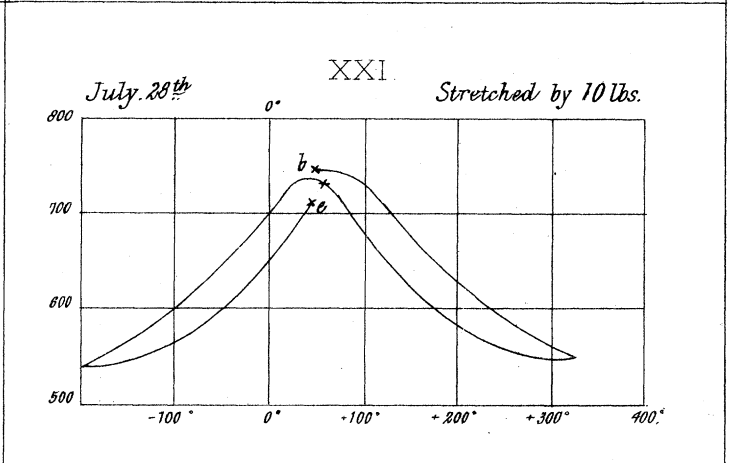
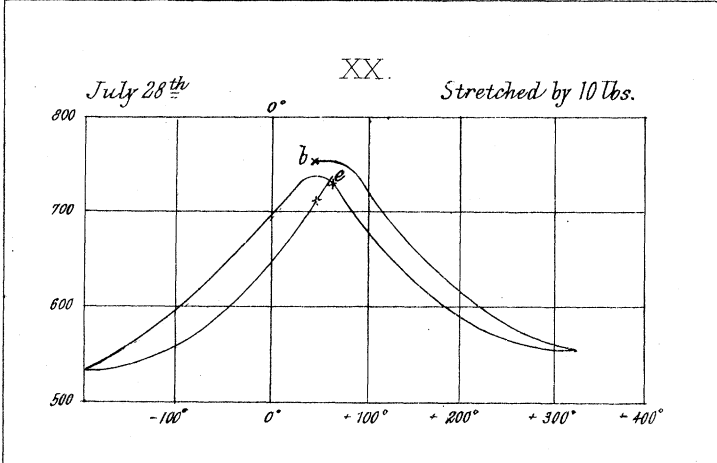
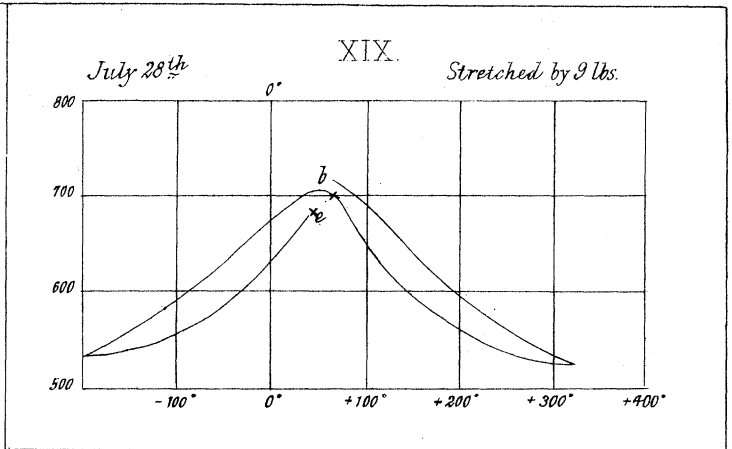
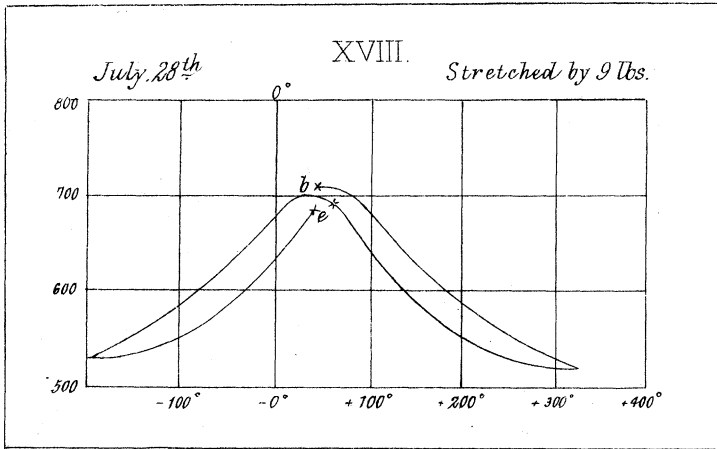

XXV.
Weight 20 lbs.

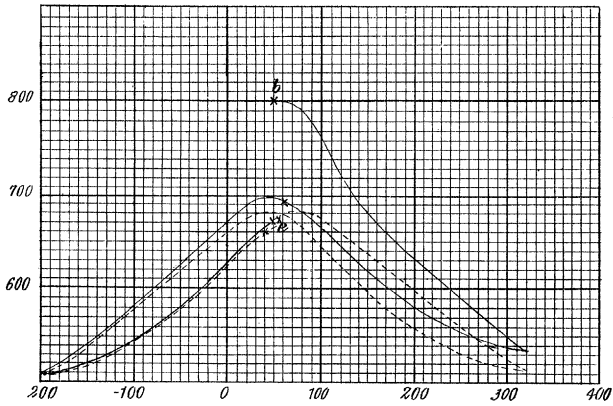

XXVI.
Weight 22 lbs.

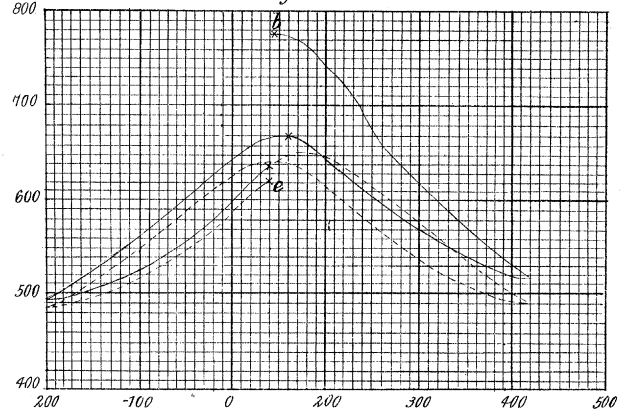

XXVII.
Weight 24 lbs.

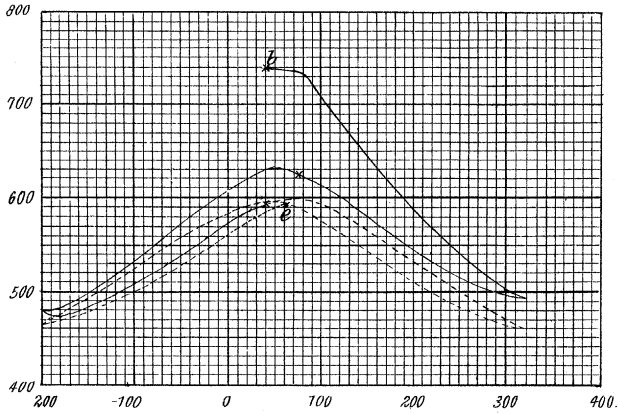

XXVIII.
Weight 26 lbs.

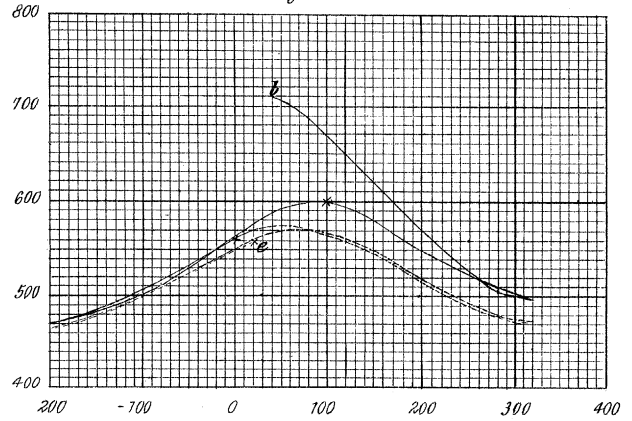

XXIX.
Weight 28 lbs.

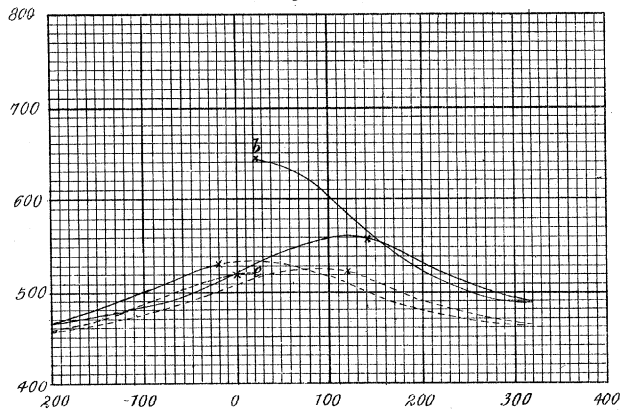

Diagram XXIV.

August 2, 11^h 5^m to 12^h 40^m.

Stretching weight, 18 lbs.

Zero of magnetometer, at end 95.

Diagram XXV.

August 2, 4^h 0^m to 5^h 20^m.

Stretching weight, 20 lbs.

Zero of magnetometer, at beginning 95, at end 85.

Diagram XXVI.

August 3, 10^h 25^m to 11^h 45^m.

Stretching weight, 22 lbs.

Zero of magnetometer, at end 90.

Diagram XXVII.

August 3, 12^h 0^m to 1^h 50^m.

Stretching weight, 24 lbs.

Zero of magnetometer, at beginning 90, at end 100.

Diagram XXVIII.*

August 3, 4^h 0^m to 5^h 30^m.

Stretching weight, 26 lbs.

Zero of magnetometer, at end 90.

Diagram XXIX.

August 4, 12^h 20^m to 1^h 50^m.

Stretching weight, 28 lbs.

Zero of magnetometer, at beginning 90, at end 100.

225. From the curves it will be seen that the amount of the effect of torsion in diminishing the magnetization is not greatly influenced by the differences of pull from 10 lbs. to 20 lbs., but that it is greatly diminished by increase of the pull above 20 lbs. For simplicity and uniformity in the comparison, take the amount of the diminution of magnetization by the first application of torsion in the direction called negative, from the whole range of from $+50^\circ$ to -200° on the scale of torsion (abscissas of the curves).

We find with pulls of from 10 lbs. to 20 lbs. various amounts of from 180 to 230 magnetometer scale divisions. The seemingly irregular differences between these amounts showed no regular dependence on the amount of pull, but seemed rather to depend upon previous conditions of the wire. But when the weight exceeded 20 lbs. there seemed a somewhat regular diminution in the effect of torsion with increase of pull, as shown in the following table ; thus:—

With pull of 20 lbs. the effect was 193			
„	22	„	177
„	24	„	150
„	26	„	130
„	28	„	65

* In this diagram the two dotted lines between $+40$ and -200 coincide.

226. One very interesting feature common to all the diagrams, and presented even to some degree by the exceptional ones 9, 10, 12, and 14, shows that the effect of twisting the wire first in one direction and then in the other, and leaving it free from torsive force, was in every case to leave it with less magnetization than it had at the beginning.

227. These exceptional diagrams and later continuation of the operations through a second positive torsion and a second negative torsion, represented in the latter halves of the curves of Diagrams XXIV. to XXIX., show what would be the general character of the effect of continued periodic applications of positive and negative torsion, through equal angles on the two sides of zero.

In every case there is a lagging of quality, showing a residue of effect from previously acting causes. Thus, beginning with a wire which has been reduced to a normal condition by having had the weight off and on, and having been left to itself for twenty-four hours, we found on the 24th of August that the magnetization fell from a normal value of 685 down to 550 as the result of twisting it to $+260^{\circ}$ then to -260 , and then to zero of torsion. The second application of positive and negative torsion reduced the magnetization further to 534. It is curious to find that not merely does torsion diminish the magnetization temporarily, but that it leaves so large a permanent diminution. Whether this permanence is absolute in respect to time or not is an interesting question to be solved by leaving a wire which has been thus dealt with absolutely quiescent from day to day, month to month, year to year, century to century. It seems, however, that but slight mechanical disturbance suffices to shake out the diminution of magnetization left at the end of each of these experiments.

228. The general lagging of effect is shown by the fact that in every ascending branch the curve is lower than in the immediately previous descending branch; and the dotted latter halves of the long curves of the Diagrams XXIV. to XXIX. show, by the intersections of their convex portions near the zero, that if the experiment was continued long enough, the history of the variation of magnetization would in every case be represented by a curve like that in the annexed sketch.

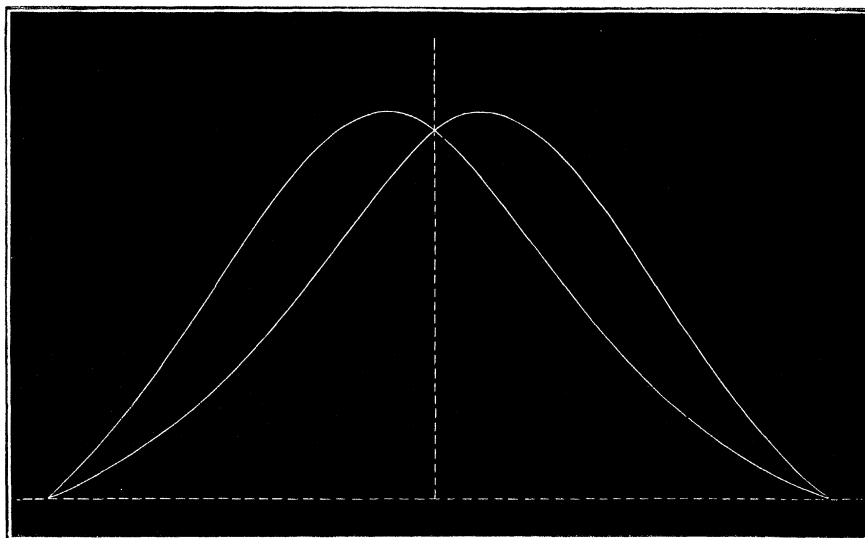

229. A very interesting discovery of WIEDEMANN'S ('Galvanismus,' §§491 and 498), at first sight, seemed to find its explanation in the aeolotropic difference of magnetic susceptibility which I have found to be induced by aeolotropic stress in soft iron. The phenomenon consists in the development of longitudinal magnetization by twisting a wire through which a magnetic galvanic current is maintained longitudinally. The annexed double diagram, copied from WIEDEMANN'S book,* describes the change of

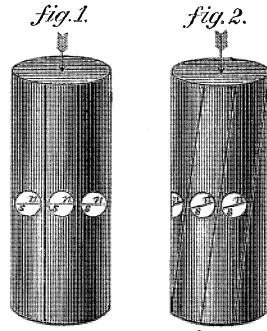

ideal magnetic molecules which would represent the actually observed effect, which is that the end of the wire by which the current enters becomes a true north pole when the twist given to it is right-handed (or that of an ordinary screw). If this effect were due to greater susceptibility in one direction than in another, the direction of greatest susceptibility would be the direction sloping at 45° , upwards to the right in the front of the right-hand diagram; that is to say, it would be the direction of positive pull in the stressed material. But the exceedingly intense magnetization by influence of circular lines of force round the cylinder, produced by currents of such strength as WIEDEMANN may be supposed to have used, must in all probability have been above the critical degree of magnetization at which the effect of pull becomes reversed, and therefore in all probability the direction of least susceptibility in the actual circumstances must have been that of positive pull. Hence, it seems almost impossible to admit the explanation of WIEDEMANN'S result by aeolotropic magnetic susceptibility in the circumstances.† The true explanation is not easily conjectured: for another cause, also adverse to WIEDEMANN'S result, is operative. The electric conductivity of the iron is probably least in the direction of the positive pull and greatest in the direction of the negative pull in the stressed material.‡ This aeolotropic quality in

* I have altered the letters *n* and *s* of WIEDEMANN'S book to GILBERT'S old wholesome rule of putting *n* to represent true northern polarity, or the polarity of the same name as that of the earth's northern regions, and similarly *s* to represent true southern polarity.

† This experiment has been repeated for me since the communication of this instalment to the Royal Society, by Mr. MACFARLANE, with currents, not hitherto measured or estimated in absolute measure, but strong enough to greatly heat the iron wire. The result was always the same as WIEDEMANN'S, and was greatest with the strongest current used.—(W. T., May 22, 1878.)

‡ "Electrodynamic Qualities of Metals," §§ 145—153 (W. THOMSON, Transactions of the Royal Society, 1856). "On the Increase in Resistance to the Passage of an Electric Current produced in Certain Wires by Stretching" (TOMLINSON, Proc. Roy. Soc., No. 183, 1877).

respect to electric conductivity would cause the electric current, instead of flowing rectilinearly along the wire, to flow in left-handedly helical lines in the case represented in fig. 2, and thus the central parts of the iron cylinder would become really magnetized by, as it were, an ordinary helix, but with very steep thread. The effect of such a helix is the same as that of a true solenoid superimposed upon a rectilinear current through the wire, and the direction of the current in the supposed circumstances is such that it would give a true south pole at the upper end of the iron rod in fig. 2.

(Received and read May 23, 1878.)

§§ 230–240. *On the effects of longitudinal stress on the Magnetization of Nickel and Cobalt.*

§ 230. Through the kindness of MR. JOSEPH WHARTON, of Philadelphia, U.S., I was enabled to continue my experiments with malleable and cast bars of nickel, and of cast cobalt.

[Note added July 8, 1879.—A qualitative analysis of one of Mr. WHARTON'S nickel bars, performed in the Chemical Laboratory of Glasgow University, by Mr. DONALD MACKENZIE, showed that the bar was not of absolutely pure nickel, but contained some carbonaceous matter and also a trace of iron. The amount of the latter, however, was very small, and probably could not vitiate to any sensible degree the results of the experiments described below.]

The apparatus used in the preliminary experiments and its arrangement are shown in the annexed diagram (XXX.). Each end of the rod experimented on was inserted into a ferule-shaped clamp, C (shown also detached in plan and elevation), the outer surface of which was conical and screw-threaded.

The clamp, which had in it three longitudinal slits, was then, by means of a conical nut working round it, made to grasp the rod tightly enough to admit of the application of great amounts of longitudinal pull, without much danger of pulling the clamps away from the rod. One of the clamps was then hung from a pin in a strong cross-beam of a frame, so that the bar hung vertically downwards.

A rope, R, made of copper wire, connected the other clamp with a point near the end of a long heavy lever, turning on a fulcrum at that end formed by a knife edge pressing upwards against a brass plate, which formed a bridge between two strong and rigid uprights attached to the floor of the room. A heavy weight of lead was hung on the lever, and could be slid along it to give different amounts of stress. The lever was graduated, and the effect of its own weight was measured, so that the stress applied at any time could be at once read off. When the bar was in position but not under stress, the lever rested on a support high enough to allow the wire rope R to be slack, and was gently removed from this support when the pulling stress was applied.

XXXX.

Clamp.
Half Stone.

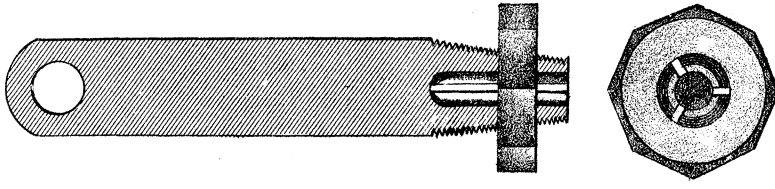
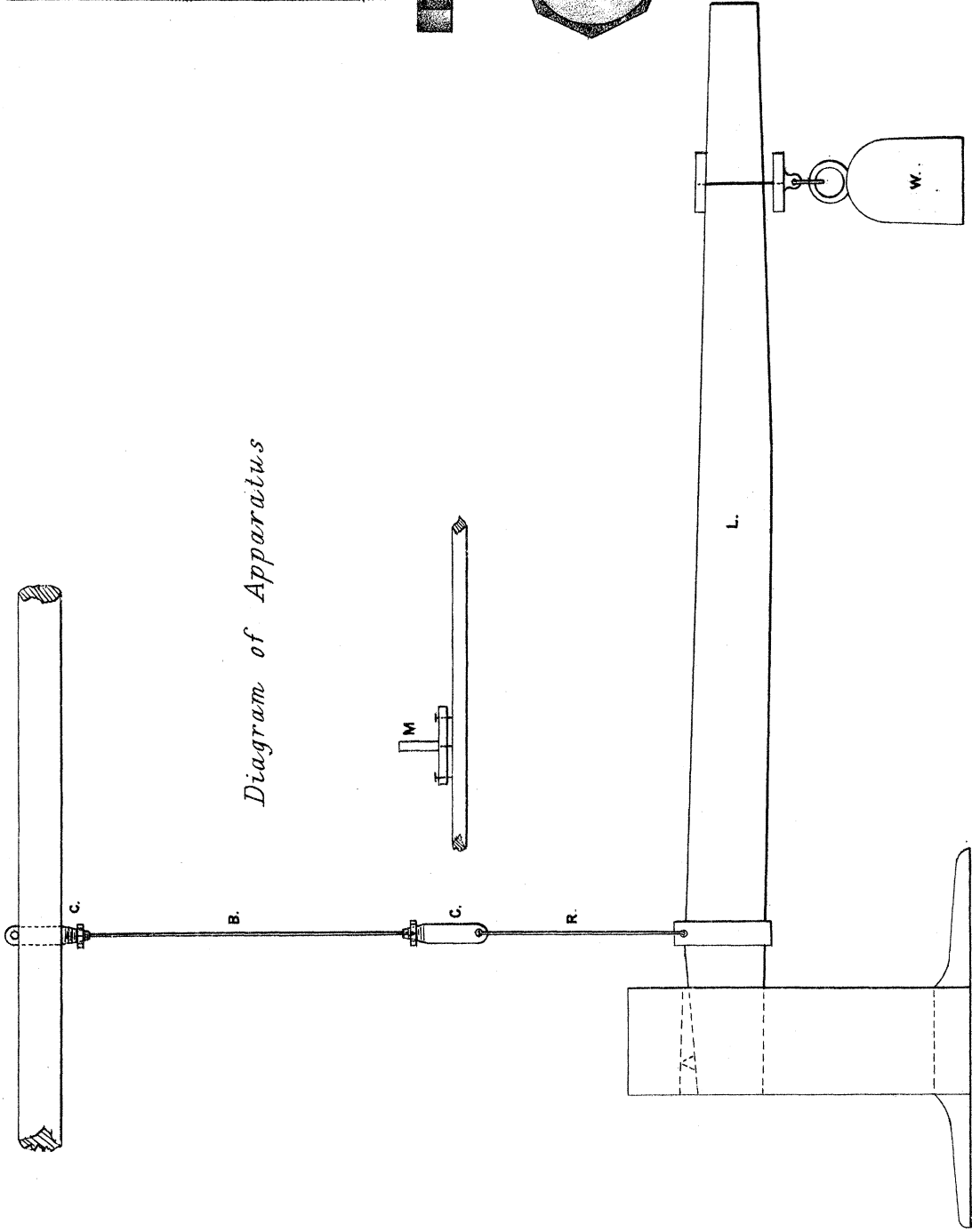

Diagram of Apparatus



The effects of the various operations were measured by the deflections of the image on the scale of a reflecting magnetometer, M, the needle of which was on a level with the lower end of the bar, and at a distance due magnetic west from its axis of 12 centims. The scale of the magnetometer was at a distance of 135 centims. from the needle.

231. In these preliminary experiments the bars were under the influence of no magnetizing force except that of the vertical component of the earth's magnetic force at Glasgow. In order that the results obtained with the bars of nickel and cobalt might be readily compared with those obtained from iron in the same circumstances, the experiment was first performed on a bar of tolerably soft iron, of nearly the same dimensions as those of the bar of nickel or cobalt experimented on. The actual results of a set of these experiments are given in the following tables. Table I. contains the results of an experiment on an iron bar 60 centims. long and .8 of a centim. in diameter, and Tables II. and III. the results respectively of two similar experiments performed immediately afterwards, one on a bar of wrought nickel and the other on a bar of cast cobalt. The total magnetization is reckoned positive when its polarity is the same as that produced by the inductive effect of the earth's magnetic force, and negative when its polarity is of the opposite kind.

TABLE I.—Iron Bar. Lower end of bar a true South Pole.

Operations.	Magnetometer readings.	Differences.	Total magnetization.
Bar placed in position . . .	Zero 463 Image off scale in negative direction		
Controlling magnet introduced	769		+1369
174 lbs. on	675	-94	+1463
" off	687	+12	+1451
" on	660	-27	+1478
" off	675	+15	+1463
10 "ons" and "offs" .	667	- 8	+1471
174 lbs. on	649	-18	+1489
" off	663	+14	+1475
259 lbs. on	571	-92	+1567
" off	597	+26	+1541
10 "ons" and "offs" .	570	-27	+1568
259 lbs. on	540	-30	+1598
" off	569	+29	+1569
325 lbs. on	470	-99	+1668
" off	510	+40	+1628
10 "ons" and "offs" .	474	-36	+1664
325 lbs. on	421	-53	+1717
" off	457	+36	+1671

TABLE II.—Wrought Nickel Bar. Lower end a true South Pole.

Operations.	Magnetometer readings.	Differences.	Total magnetization.
	Zero 460		
Bar placed in position . . .	450	-10	+ 10
146 lbs. on	421	-29	+ 39
" off	411	-10	+ 49
" on	416	+ 5	+ 44
" off	410	- 6	+ 50
Clamp here slipped.			
Bar reclamped and replaced	Image at		
in position	415	-45	+ 95
146 lbs. on	412	- 3	+ 98
" off	393	-19	+117
" on	410	+17	+100
" off	389	-21	+121
10 "ons" and "offs"	387	- 2	+123
146 lbs. on	410	+23	+100
" off	388	-22	+122
174 lbs. on	408	+20	+102
" off	384	-24	+126
10 "ons" and "offs"	383	- 1	+127
174 lbs. on	405	+22	+105
" off	380	-25	+130
211 lbs. on	405	+25	+105
" off	376	-29	+134
10 "ons" and "offs"	375	- 1	+135
211 lbs. on	403	+28	+107
" off	378	-25	+132
249 lbs. on	403	+25	+107
" off	368	-35	+142
10 "ons" and "offs"	375	+ 7	+135
249 lbs. on	395	+20	+110
" off	365	-30	+140
" on	398	+33	+107
" off	364	-34	+141
287 lbs. on	397	+33	+108
" off	357	-40	+148
10 "ons" and "offs"	353	- 4	+152
287 lbs. on	393	+40	+112
" off	350	-43	+155

TABLE III.—Cast Cobalt Bar. Lower end at first a true *North* Pole.

Operations.	Magnetometer readings.	Differences.	Total magnetization.
	Zero 460		
Cobalt bar placed in position	952	+ 492	- 492
146 lbs. on	895	- 57	- 435
" off	885	- 10	- 425
10 " ons" and " offs"	867	- 18	- 407
146 lbs. on	882	+ 15	- 422
" off	867	- 15	- 407
Bar struck a few blows with a mallet. Magnetism reversed	370	- 497	+ 90
146 lbs. on	395	+ 25	+ 65
" off	370	- 25	+ 90
" on	395	+ 25	+ 65
" off	373	- 22	+ 87
174 lbs. on	403	+ 30	+ 57
" off	375	- 28	+ 85
10 " ons" and " offs"	375	0	+ 85
249 lbs. on	Bar here broke, but being held in its place gave a reading of 360		

232. In Table I. it is stated that when the iron bar was placed in position the image on the scale of the magnetometer was driven off the scale in the negative direction. A controlling magnet, 15 centims. long, placed at right angles to the magnetic meridian in a horizontal line passing through the centre of the needle, was used to bring the image to the division 769 on the scale. When the nearer end of this magnet was at a distance of 23 centims. from the needle, the image rested at the division 323 on the scale, and when the magnet was brought 6 centims. nearer to the needle, at the division 773 on the scale. Hence, taking the tangent of the angle of deflection as equal to the angle itself, we may reckon the deflection caused by bringing the iron bar of Table I. into position as 1369 scale divisions, which may be taken as measuring the magnetism of the bar.* This increased during twelve successive

* The method of calculation is as follows:—Let A denote the deflection produced by placing the bar in position; D and D' the readings with the controlling magnet introduced, with its centre at the distances r and r' from the magnet; a the half length of the magnet; and B a constant depending on the controlling magnet; then we have,

$$D = A + \frac{B}{(r-a)^2} - \frac{B}{(r+a)^2} = A + \frac{4Bar}{(r^2-a^2)^2}$$

and similarly

$$D' = A + \frac{4Bar'}{(r'^2-a^2)^2}$$

Eliminating B between these two equations, and solving for A we get

$$A = \frac{D+D'}{2} - \frac{D-D'}{2} \frac{r(r'^2-a^2)^2 + r'(r^2-a^2)^2}{r(r'^2-a^2)^2 - r'(r^2-a^2)^2}$$

By taking for a the virtual half length of the magnet or the distance of either pole from the centre of

applications and removals of a pulling stress of 174 lbs. to about 1470 scale divisions, when the bar was found to have been brought to a nearly permanent condition; and the average effect of applying this stress was to increase the magnetism by 16 divisions, and of removing the stress to diminish the magnetism by the same amount. The magnetism of the bar further increased during 11 successive applications and removals of a pull of 259 lbs. to 1568 scale divisions, and the average effect of applying and removing the pull was to increase and diminish the magnetism by 28 scale divisions. After 11 applications and removals of a stress of 325 lbs. the magnetism was found to have increased to 1664 divisions; and the average effect of "on" and "off" was found to be an increase and diminution of 45 divisions.

233. Passing now to the nickel bar of Table II., we see that when the bar was placed in position it showed 10 divisions of positive magnetism (or magnetism of the same polarity as that induced by the earth). The application of 146 lbs. of pull gave it 29 divisions, and the removal of this pull 10 divisions additional magnetism, that is, both "on" and "off" increased the magnetism. A second application of the pull gave a diminution of 5, and removal an increase of 6 divisions. The remainder of the procedure was similar to that followed in the case of the soft iron, and with the exception of the first result after the bar was placed in the clamps, the effect of "on" was always to *diminish* the magnetism of the bar, and of "off" to *increase* it.

After the bar was placed in the clamps the effect of the successive operations was on the whole to gradually augment the total magnetization of the bar from the value 10 to the value 155, at which it stood when the experiment was concluded.

234. From Table III. we see that the bar of cast cobalt, when placed in position, had its true north pole down, and gave a deflection of 392 divisions. Ten "ons" and "offs" with 136 lbs. diminished this deflection by 85 divisions. The effect of "on" was then to *increase* the magnetism by 15 divisions, and of "off" to *diminish* it by the same amount; that is to say, "on" increased the magnetism of the bar, "off" diminished it. A few blows of a mallet reversed this magnetism, and caused the bar to give a deflection of 90 divisions in the opposite direction. The effect of "on" was, as with the nickel bar, to *diminish* the magnetism, and of "off" to *increase* it, the effect of 146 lbs. being 25 divisions of the magnetometer scale, of 174 lbs. 29 divisions. The bar broke before the effect of the application of 249 lbs. could be observed. After the reversal of the magnetism by tapping the bar while under the influence of the vertical component of the earth's magnetic force, there was very little gradual change in the magnetization of the bar.

The seemingly anomalous effect obtained with the cobalt bar, when placed with its true north pole down, according to which the effect of the application of stress was to increase the magnetism of the bar, and of the removal of stress to diminish it,

the magnet's length, instead of the actual half length, a somewhat nearer approximation to the value of A might have been obtained, but, as the approximation was at best a rough one on account of the size of the angle, it was not thought necessary to make this refinement.

was no doubt due to the magnetizing influence of the earth tending to reverse the retained magnetism of the bar. It will be further investigated in a continuation of experiments on cobalt.

235. The effect of longitudinal stress on the magnetization of nickel when magnetized by a current flowing in a coil surrounding the bar formed the subject of the next series of investigations. The magnetizing coil was 54 centims. long, and consisted of six layers of silk-covered copper wire of No. 22 B.W.G., each layer forming a solenoid containing 10·7 turns per centim. The resistance of the coil when cool was 7·2 ohms, and the resistance of the electrodes ·3 of an ohm. In this experiment the magnetometer was placed at a distance of 40 centims. from the axis of the bar, and on a level with its lower end; and in order that the deflection due to the total magnetization of the bar might be conveniently measured, the directive force on the magnetometer needle was increased by placing behind it, in the magnetic meridian, a bar magnet, with its true north pole turned towards the north. As in the previous experiments with iron and steel, $-M$ indicates that the electromagnetic field was opposite in polarity to that of the earth, and $+M$ that its polarity was the same as that of the earth. The dead-beat galvanometer used in the experiments on the effects of transverse stress on the magnetization of an iron tube was again employed to measure the strength of the magnetizing current.

236. The results of a series of these experiments are given in Table IV. It will be seen from that table that the effects of the application and removal of stress were respectively to diminish and to increase the induced magnetization, and that, as in the case of soft iron, this effect reached a maximum with a certain strength of magnetizing current, after which it slowly diminished. In this experiment the critical value of the magnetizing force corresponding to what has been called above, in the account of experiments in soft iron, the VILLARI *critical value*, was not reached.

TABLE IV.—Bar of Wrought Nickel.

Operations.	Readings. Zero 554.	Differences.	Total magnetization.	Strength of magnetizing current.
Bar put in position	352	-202	+202	62 (2 double cells)
-M	583	+231	-29	
10 "ons" and "offs" with 285 lbs.	637	+54	-83	
285 lbs. on	623	-14	-69	
" off	637	+14	83	
B	568	-69	-14	
285 lbs. on	554	-14	0	
" off	556	+2	-2	
" on	553	-3	+1	
" off	555	+2	-1	

TABLE IV.—Bar of Wrought Nickel.—continued.

Operations.	Readings. Zero 554.	Differences.	Total magnetization.	Strength of magnetizing current.
+ M	340	-215	+214	62
285 lbs. on	367	+ 27	+187	
„ off	332	- 35	+222	
„ on	363	+ 31	+191	
„ off	329	- 34	+225	
„ B	388	+ 59	+166	
285 lbs. on	426	+ 38	+128	
„ off	403	- 23	+151	
„ on	427	+ 24	+127	
„ off	404	- 23	+150	
- M	863	+459	-309	147
285 lbs. on	832	- 31	-278	
„ off	864	+ 32	-310	
„ on	833	- 31	-279	
„ off	864	+ 31	-310	
„ B	745	-119	-191	
285 lbs. on	690	- 55	-136	
„ off	716	+ 26	-162	
„ on	689	- 27	-135	
„ off	716	+ 27	-162	
+ M	226	-490	+328	147
285 lbs. on	260	+ 34	+294	
„ off	227	- 33	+327	
„ on	260	+ 33	+294	
„ off	226	- 34	+328	
„ B	343	+117	+211	
285 lbs. on	400	+ 57	+154	
„ off	370	- 30	+184	
„ on	400	+ 30	+154	
„ off	371	- 29	+183	
- M	953	+582	-399	282
285 lbs. on	927	- 26	-373	
„ off	950	+ 23	-396	
„ on	925	- 25	-371	
„ off	950	+ 25	-396	
„ B	777	-173	-223	
285 lbs. on	715	- 62	-161	
„ off	746	+ 31	-192	
„ on	715	- 31	-161	
„ off	744	+ 29	-190	
+ M	155	-589	+399	282
285 lbs. on	181	+ 26	+373	
„ off	156	- 25	+398	
„ on	182	+ 26	+372	
„ off	156	- 26	+398	
„ B	327	+171	+227	
285 lbs. on	388	+ 61	+166	
„ off	357	- 31	+197	
„ on	388	+ 31	+166	
„ off	358	- 30	+196	
Zero changed to	500	Difference from zero		432
- M	940	440	-440	
285 lbs. on	925	- 15	-425	
„ off	940	+ 15	-440	

TABLE IV.—Bar of Wrought Nickel.—continued.

Operations.	Readings. Zero 500.	Differences.	Total magnetization.	Strength of magnetizing current.
285 lbs. on	923	— 17	—423	
" off	939	+ 16	—439	
" B	726	—213	—226	
285 lbs. on	665	— 61	—165	
" off	697	+ 32	—197	
" on	664	— 33	—164	
" off	696	+ 32	—196	
" +M	48	—648	+452	432
285 lbs. on	63	+ 15	+437	
" off	48	— 15	+452	
" on	63	+ 15	+437	
" off	47	— 16	+453	
" B	268	+221	+232	
285 lbs. on	329	+ 61	+171	
" off	297	— 32	+203	
" on	330	+ 33	+170	
" off	298	— 32	+202	
" +M	13	—285	+487	580
285 lbs. on	25	+ 12	+475	
" off	16	— 9	+484	
" on	28	+ 12	+472	
" off	18	— 10	+482	
" B	268	+250	+232	
285 lbs. on	334	+ 66	+166	
" off	299	— 35	+201	
" on	334	+ 35	+166	
" off	299	— 35	+201	
" —M	963	+664	—463	580
285 lbs. on	954	— 9	—454	
" off	963	+ 9	—463	
" on	952	— 11	—452	
" off	961	+ 9	—461	
" B	724	—237	—224	
285 lbs. on	664	— 60	—164	
" off	697	+ 33	—197	
" on	663	— 34	—163	
" off	696	+ 33	—196	
Reading brought to	617			
—M	900	+283	—479	708
285 lbs. on	892	— 8	—471	
" off	897	+ 5	—476	
" on	889	— 8	—468	
" off	897	+ 8	—476	
" B	645	—252	—224	
285 lbs. on	582	— 63	—161	
" off	616	+ 34	—195	
" on	582	— 34	—161	
" off	615	+ 33	—194	
Reading brought to	765			
+M	74	—691	+497	708
285 lbs. on	81	+ 7	+490	
" off	76	— 5	+495	
" on	83	+ 7	+488	
" off	76	— 7	+495	

TABLE IV.—Bar of Wrought Nickel—concluded.

Operations.	Readings.	Differences.	Total magnetization.	Strength of magnetizing current.
361 lbs. on	92	+ 16	+479	708
„ off	80	− 12	+491	
„ on	93	+ 13	+478	
„ off	80	− 13	+491	
285 lbs. on	91	+ 11	+480	
* „ off	85	− 6	+486	
„ on	94	+ 9	+477	
„ off	85	− 9	+486	
211 lbs. on and off 5 times	90	+ 5	+481	
211 lbs. on	96	+ 6	+475	
„ off	90	− 6	+481	
„ on	96	+ 6	+475	
„ off	91	− 5	+480	
136 lbs. on	96	+ 5	+475	
„ off	93	− 3	+478	
„ on	97	+ 4	+474	
„ off	93	− 4	+478	
„ B	350	+257	+221	
136 lbs. on	380	+ 30	+191	
„ off	363	− 17	+208	
„ on	384	+ 21	+187	
„ off	365	− 19	+206	
„ on	384	+ 19	+187	
„ off	365	− 19	+206	
361 lbs. on	418	+ 53	+153	
„ off	377	− 41	+194	
„ on	420	+ 43	+151	
„ off	379	− 41	+192	
285 lbs. on	412	+ 33	+169	
„ off	379	− 33	+202	
„ on	411	+ 32	+170	
„ off	378	− 33	+203	

237. The preceding table shows that the effect of the application of pull was to diminish, and of the removal of pull to increase the magnetism of the bar, whether induced or residual; and that a series of these operations *increased* on the whole the magnetism induced by $+M$ or $-M$, but diminished on the whole the residual magnetism after B. Further, as stated above, the effect of “on” or “off” on the induced magnetism of the bar increases up to a certain point, and then diminishes as the magnetizing force is increased from zero upwards; while, on the other hand, the effect of “on” or “off” on the residual magnetism goes on increasing as the residual magnetism is increased, and, as does also the residual magnetism, approaches more and more to a certain constant value.

238. On account of the thickness of the bar, a large amount of wire was required to make a coil which would give a sufficiently powerful magnetizing force to reach or pass the critical value to which the magnetizing force seemed in the preceding experiments

to approach. It was found more convenient to continue the experiment with a smaller bar of nickel, kindly lent for the purpose by Professor TAIT. This (which was a square bar 45.7 centims. long and .30 centim. thick) was placed within a coil wound on a thin copper tube of just sufficient internal diameter to admit the bar. The coil contained six layers of silk-covered copper wire, of No. 22 B.W.G., each layer forming a solenoid 42.7 centims. long, containing 10.7 turns per centim. The total resistance of the coil when cool was 4.33 ohms. The resistance of the electrodes was, as before, .3 of an ohm. The magnetometer needle was in this case placed on a level with the upper end of the bar, and at a distance of 25 centims. from the axis of the bar, and of 108 centims. from the scale of half millims. on which the readings were observed. The stress was not applied by means of the lever, but a weight of 14 lbs. was placed on a pan attached to the bar. This pan, which weighed 1 lb., was left hanging on the bar during the whole experiment.

239. In their general character the results are precisely similar to those shown in Table IV. A maximum effect of 20 divisions was obtained when the magnetizing force was 194 divisions of the battery galvanometer scale, or that due to about 4 cells. As the magnetizing force was increased beyond this value the effects obtained gradually diminished, and seemed to reach zero when the magnetizing force was about 1000 divisions, or that due to about 40 cells. The results at this point could not, on account of variations of the magnetizing force due to heating of the coil, be relied on as being accurate.

[Note added June 4, 1879.—This result has not been confirmed by experiments lately made with improved apparatus in which the effects of the heating of the magnetizing coil, formerly a great source of trouble, were to a great extent prevented. No sign of a neutral point was found, although battery powers of from 5 to 79 tray cells were employed for the purpose of magnetizing the nickel bar, which was the actual bar formerly experimented on.]

240. An experiment was then made to find whether this critical value could, as in the case of the soft iron tube, be obtained with a smaller degree of magnetizing force when the magnetometer was placed on a level with a point between the middle and end of the bar. Accordingly, the magnetometer was lowered 10 centims., and brought to a distance of 10 centims. from the axis of the bar. The scale was left in its former position, and thus the distance of the mirror from it was increased to 123 centims. The directive force on the needle was also increased to 6.08 times that due to the horizontal component of the earth's magnetic force. The maximum effect of the application and removal of stress was obtained with a magnetizing force of 50 scale-divisions, or that due to 1 cell. And the critical value was found without difficulty to be 428 divisions of the battery galvanometer scale, or the current due to 10 cells. Beyond that point the effect of "on" and "off" were respectively to increase and to diminish the induced magnetization of the bar, the effect with 707 divisions, or 20 cells, being about $3\frac{1}{2}$ divisions of the scale.

§§ 241–244. *Experiment by the direct Magnetometric Method on the effects of longitudinal stress on the Magnetization of Iron Wire.*

241. In this experiment the magnetizing coil described above (§ 201) was employed. The total length of the wire (which was a piece of Messrs. JOHNSON and Nephew's very soft iron wire, and cut from the same hank as that used in the former experiments) was 97 centims. As only the soldered fastenings of the wire projected beyond the ends of the coil, the magnetometer needle was placed on a level with the top of the coil, and at a distance from its axis of 25 centims., and the distance of the scale of the magnetometer from the mirror was 108 centims.

242. This experiment confirmed in all essential points the results obtained by the ballistic method in the experiments described above (§§ 200–212). The effects of applying and removing a weight of 14 lbs. were respectively to *increase* and to *diminish* by 31 divisions the magnetism induced in the wire by the vertical component of the earth's magnetic force. The amount of this induced magnetism, when only the pan was hanging on the wire, was also 31 divisions. Hence the application and removal of the 14 lbs. alternately doubled, and reduced to its previous amount, the magnetization induced by the earth's force.

When the magnetizing current was 4·25 divisions of the battery-galvanometer scale, the application and removal of pull produced no effect, thus showing that the influence of the earth's magnetizing force was exactly counterbalanced by that due to the current. The maximum effect of applying and removing stress was obtained when the magnetizing force was about 50 divisions (one cell gave 70 divisions). The VILLARI critical value was obtained with 215 divisions of magnetizing current, or 50 times the magnetizing force which balanced the influence of the earth's magnetic force. This is a much greater number than that obtained by the ballistic method; that it is so is no doubt due to the fact that the induction-coil then used was much shorter than the magnetizing coil, and was placed with the centre of its length coincident with that of the magnetizing coil. With the highest strength of current (567 divisions) the effect of "on" and "off" was 8·5 divisions, and the effects were, as in the former experiments, increasing very slowly.

243. The value in absolute units of the vertical component of the earth's magnetic force was calculated from the value of the magnetizing current which balanced it, and the total resistance of coil electrodes and battery, which were all measured for the purpose with great exactness. As before, the electromotive force of one tray cell was taken as one volt, or 10^8 on the C. G. S. system of units. The total resistance with one cell in circuit was 3·503 ohms, the number of turns per centimetre in the coil 19·628, and the fraction of the cell which gave a magnetizing force which just balanced the earth ·0607 of that due to one cell. Hence we have vertical component

$$= \frac{4\pi \times 0607 \times 10^8 \times 19\cdot628}{3\cdot503 \times 10^9} = \cdot429, \text{ which must be very nearly its true value at Glasgow.}$$

(Compare with § 207 above.)

244. It is stated above (§ 211) that the VILLARI critical value was higher for the smaller weights. This result was also verified by the magnetometric method.

The following are the numbers obtained with various amounts of pull :—

SOFT IRON WIRE.

Weights "on" and "off."	VILLARI critical value.
6 lbs.	248
10 „	227
14 „	215
18 „	190
26 „	185

VIII.

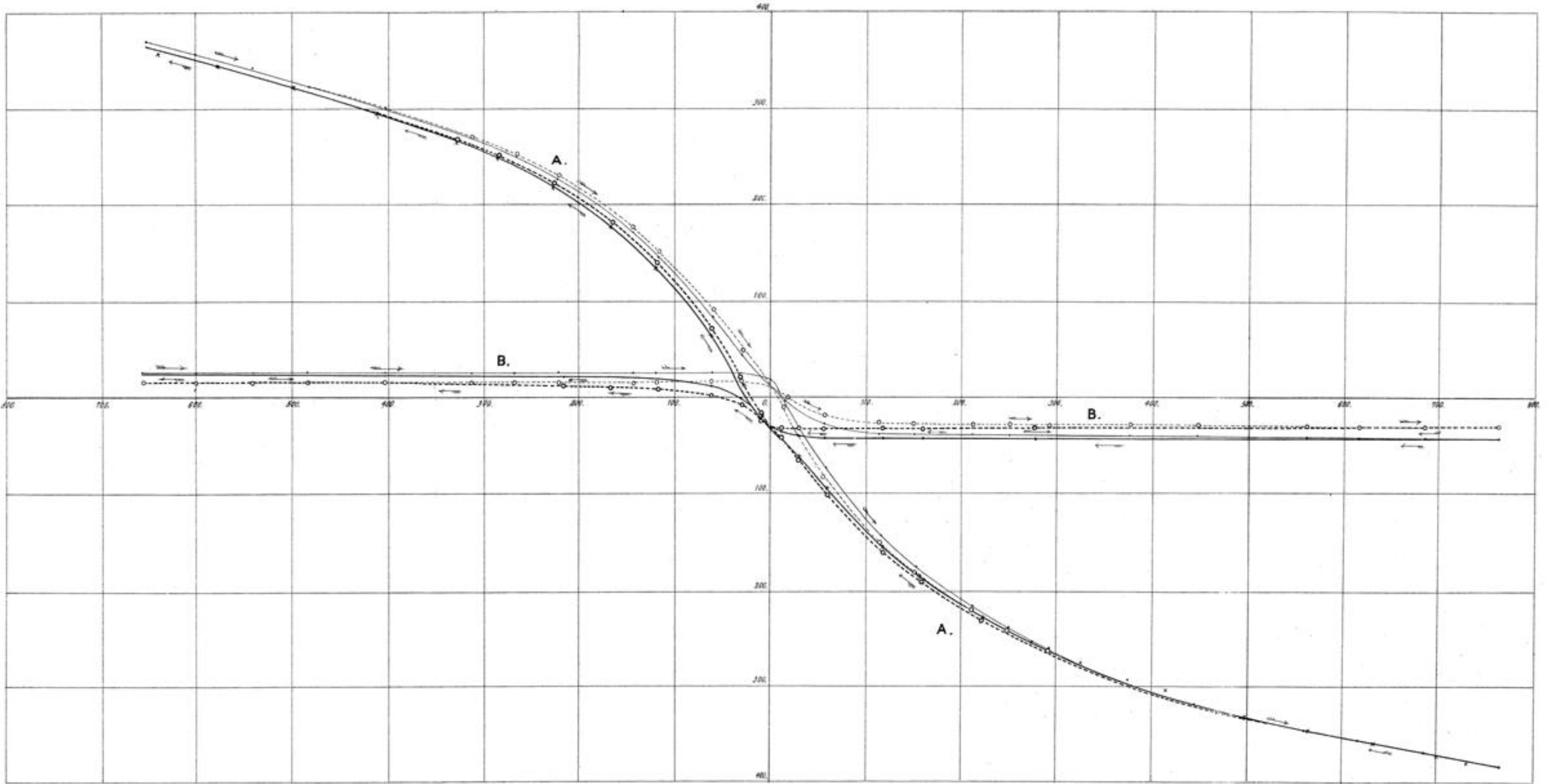

VIII.

